

# TABLETOP SOLUTIONS

---



PNP415



PNP417  
*with tabletop cutout installed.*

---

MANUAL PART NUMBER: 400-0427-002

**PNP415/417**

**POP 'N PLUG  
WITH CUSTOM TABLETOP SURFACE  
USER'S GUIDE**

---

## TABLE OF CONTENTS

---

	Page
PRECAUTIONS / SAFETY WARNINGS.....	2
GENERAL.....	2
INSTALLATION PRECAUTIONS .....	2
CLEANING.....	2
FCC NOTICE .....	2
ABOUT YOUR PNP415/417 .....	3
TECHNICAL SPECIFICATIONS.....	3
DESCRIPTION .....	4
APPLICATION DIAGRAMS.....	5
DIAGRAM 1: TYPICAL SETUP .....	5
DIAGRAM 2: CUTOUT DIMENSIONS .....	6
DIAGRAM 3: CLOSED DIMENSIONS .....	6
DIAGRAM 4: FRONT VIEW DIMENSIONS.....	7
DIAGRAM 5: SIDE VIEW DIMENSIONS.....	8
INSTALLATION PROCEDURES.....	9
OPERATION.....	9
OPENING AND CLOSING THE PNP415/417 .....	9
POWER/SIGNAL CONNECTIONS.....	9
TROUBLESHOOTING GUIDE.....	9
ALTINEX POLICIES .....	9
LIMITED WARRANTY/RETURN POLICIES .....	9
CONTACT INFORMATION .....	9

## PRECAUTIONS / SAFETY WARNINGS 1

Please read this manual carefully before using your **PNP415/417** Interconnect Box. Keep this manual handy for future reference. These safety instructions are to ensure the long life of your **PNP415/417** and to prevent fire and shock hazards. Please read them carefully and heed all warnings.

### 1.1 GENERAL

- Unauthorized personnel shall not open the unit since there are high-voltage components inside.
- Qualified ALTINEX service personnel, or their authorized representatives, must perform all service.

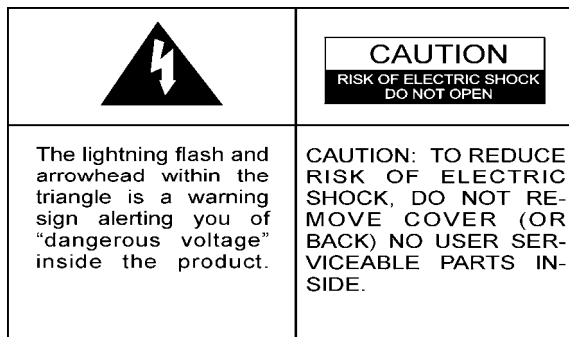

### 1.2 INSTALLATION PRECAUTIONS

- For best results, place the **PNP415/417** in a dry area away from dust and moisture.
- To prevent fire or shock, do not expose this unit to rain or moisture. Do not place the **PNP415/417** in direct sunlight, near heaters or heat-radiating appliances, or near any liquid. Exposure to direct sunlight, smoke, or steam can harm internal components.
- Handle the **PNP415/417** carefully. Dropping or jarring can damage the unit.
- Never place fingers inside the openings of the unit. This action could cause serious injury due to sharp edges inside the **PNP415/417**.
- Do not place heavy objects on top of the **PNP415/417**. Do not use excessive force to push down on the top of the unit.

- To turn off the main power, disconnect the power cord which powers the AC socket on the **PNP415/417** pop-up panel. The power outlet used should be installed as near to the equipment as possible and should be easily accessible.
- Altinex recommends using wall outlets with a Ground Fault Circuit Interrupter (GFCI) for maximum protection.
- Install all cables according to the instructions. Do not force or pull out any cable or power cord that is attached to the **PNP415/417**.

### 1.3 CLEANING

- Surfaces should be cleaned with a dry cloth. Never use strong detergents or solvents such as alcohol or thinner. Do not use a wet cloth or water to clean the unit.

### 1.4 FCC NOTICE

- This device complies with Part 15 of the FCC Rules. Operation is subject to the following two conditions: (1) This device may not cause harmful interference, and (2) this device must accept any interference received, including interference that may cause undesired operation.
- This equipment has been tested and found to comply with the limits for a Class A digital device, pursuant to Part 15 of the FCC Rules. These limits are designed to provide reasonable protection against harmful interference when the equipment is operated in a commercial environment. This equipment generates, uses, and can radiate radio frequency energy and, if not installed and used in accordance with the instruction manual, may cause harmful interference to radio communications. Operation of this equipment in a residential area is likely to cause harmful interference in which case the user will be required to correct the interference at his expense.
- Any changes or modifications to the unit not expressly approved by ALTINEX, Inc. could void the user's authority to operate the equipment.

## ABOUT YOUR PNP415/417 2

### PNP415/417

#### Pop 'N Plug with Custom Tabletop Surface

- Customizable to almost any table top
- Connector plates are fully compatible with PNP400 & PNP500 series
- Holds up to eight connector plates
- Smooth new look on all sides
- Cutout always matches
- Round, rectangular, or square cut-out
- Simple, slide-in installation
- Opens/closes by pressing on top
- Gas spring lift mechanism

This Pop 'N Plug uses a custom cut-out tabletop surface and hardware is attached underneath the cutout. When closed, the **PNP415/417** lays flat and matches the grain on your table.

Altinex provides three pre-configured templates for the **PNP415/417** cutouts: round, rectangular, and square. A simple press on the lid closes the unit flush with the tabletop.

The **PNP415/417** design allows the connector panels to be easily installed. Just remove the top and slide the connector panels into place. In the open position, the **PNP415/417** is functional yet maintains a smooth, clean appearance.

The **PNP417** comes preconfigured with two standard DS901-120 sectional plates. Each plate includes the following connections: two AC power, one 15-pin HD (video), two RJ-45 (UTP), one RJ-11 (modem), and one 3.5mm audio. There are two plates and all connectors on the plates are female receptacles. Each signal connector is connected via a six-foot cable to its corresponding male plug at the opposite end. The AC power cables are terminated with standard NEMA plugs at the end of nine-foot cords.

## TECHNICAL SPECIFICATIONS 3

Specifications are subject to change.

See [www.altinex.com](http://www.altinex.com) for up-to-date information.

FEATURES/DESCRIPTION	PNP417
<b>Inputs</b>	
Video	(2) 15 Pin HD female
Audio	(2) 3.5mm jack
Twisted Pair	(4) RJ-45 female
Modem	(2) RJ-11 female
AC Power	(4) NEMA 5-15R
<b>Outputs</b>	
Video	(2) 15 Pin HD male
Audio	(2) 3.5mm plug
Twisted Pair	(4) RJ-45 male
Modem	(2) RJ-11 male
AC Power	(4) NEMA 5-15P

Table 1. **PNP415/417** General

MECHANICAL	PNP415/417
<b>Dimensions Above Table Surface</b>	
Diameter	4.950 in. (125.7 mm)
Height, opened	4.875 in. (123.8 mm)
<b>Dimensions Below Table Bottom</b>	
Height	6.986 in. (177.4 mm)
Width	6.000 in. (152.4 mm)
Depth	3.817 in. (96.9 mm)
<b>Other Properties</b>	
Maximum weight of PNP415/417 custom top	22 oz. (0.680 kg)
Finish	Matte Black
T° Operating	10°C-35°C
T° Maximum	40°C
Humidity	90% non-condensing

Table 2. **PNP415/417** Mechanical

ELECTRICAL	PNP415/417
Power Rating (pass through AC power)	120VAC, 60Hz, 5A

Table 3. **PNP415/417** Electrical

# TABLETOP SOLUTIONS

## DESCRIPTION

4

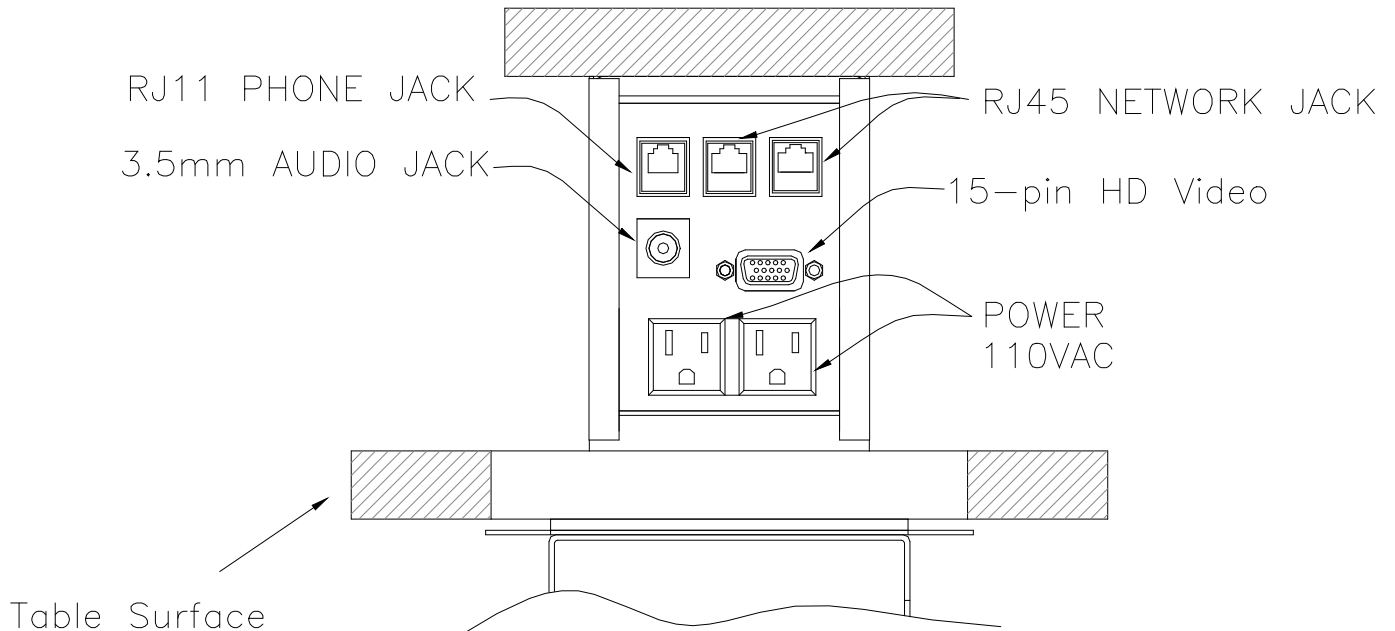

**NOTE:** The PNP417 connector installation is shown in the above diagram. Various combinations of connectors, along with the applicable cable types, may be selected for customization at the time of purchase.

Please, refer to the Altinex website ([www.altinex.com](http://www.altinex.com)) for specific customization options and instructions.

## APPLICATION DIAGRAMS

5

### DIAGRAM 1: TYPICAL SETUP

(The PNP417 is shown below.)

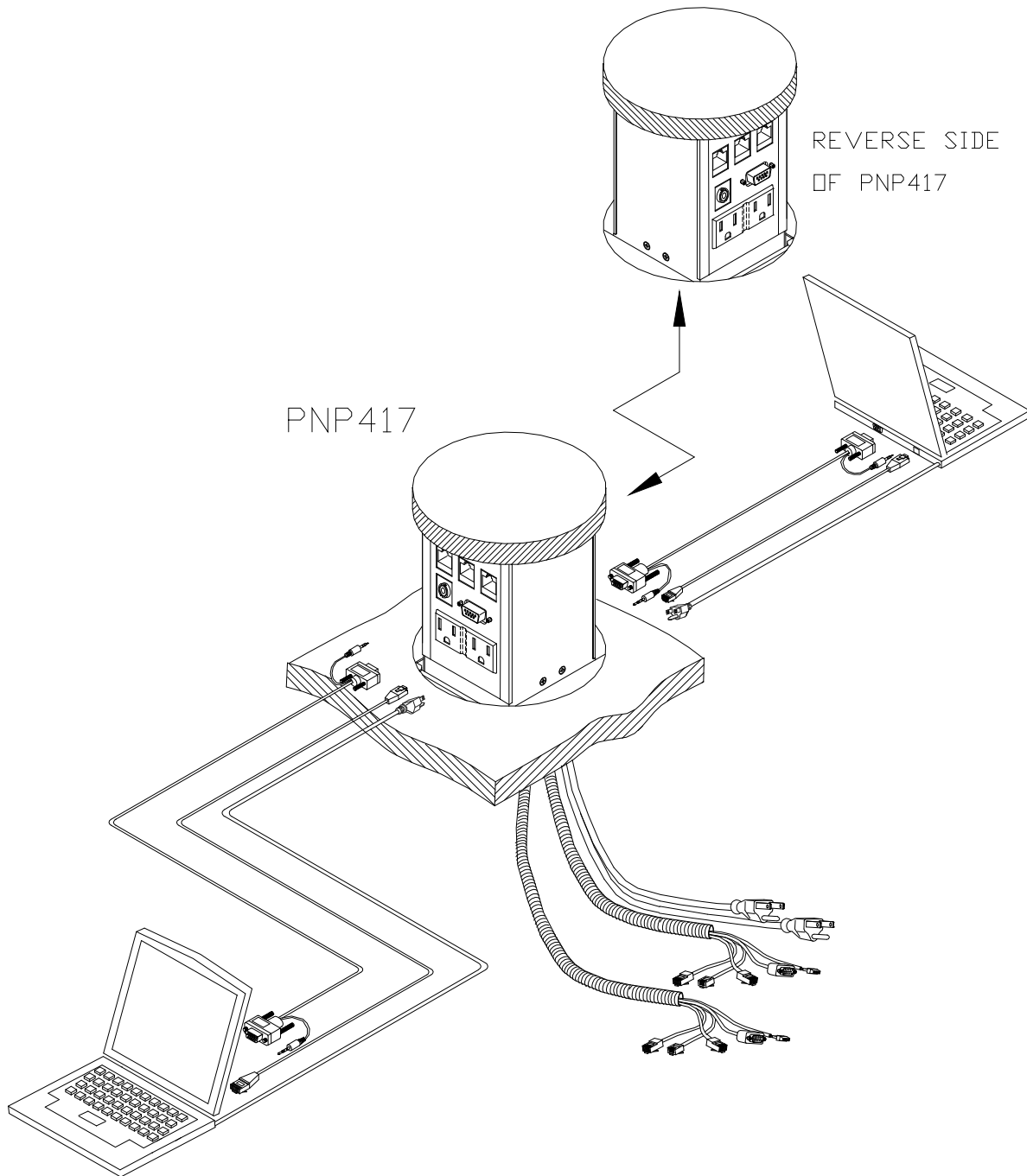

# TABLETOP SOLUTIONS

## DIAGRAM 2: CUTOUT DIMENSIONS

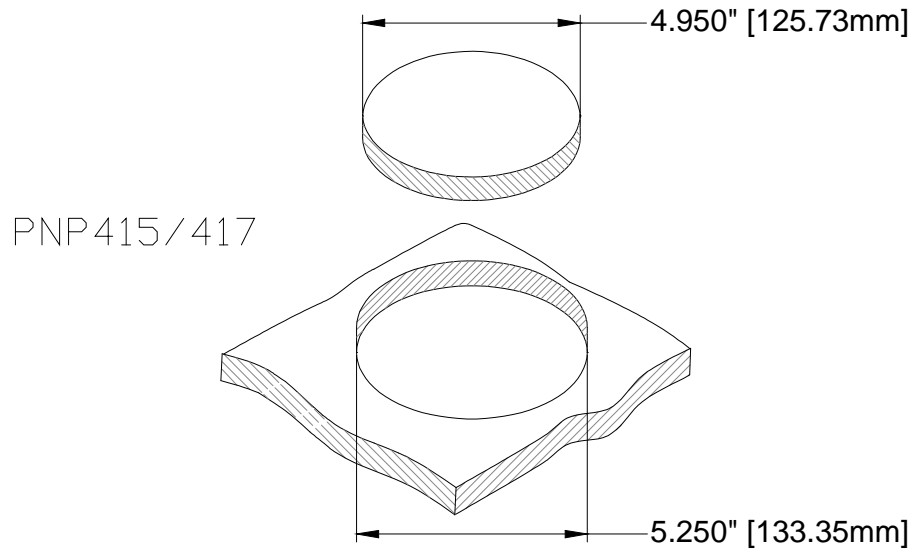

## DIAGRAM 3: CLOSED DIMENSIONS

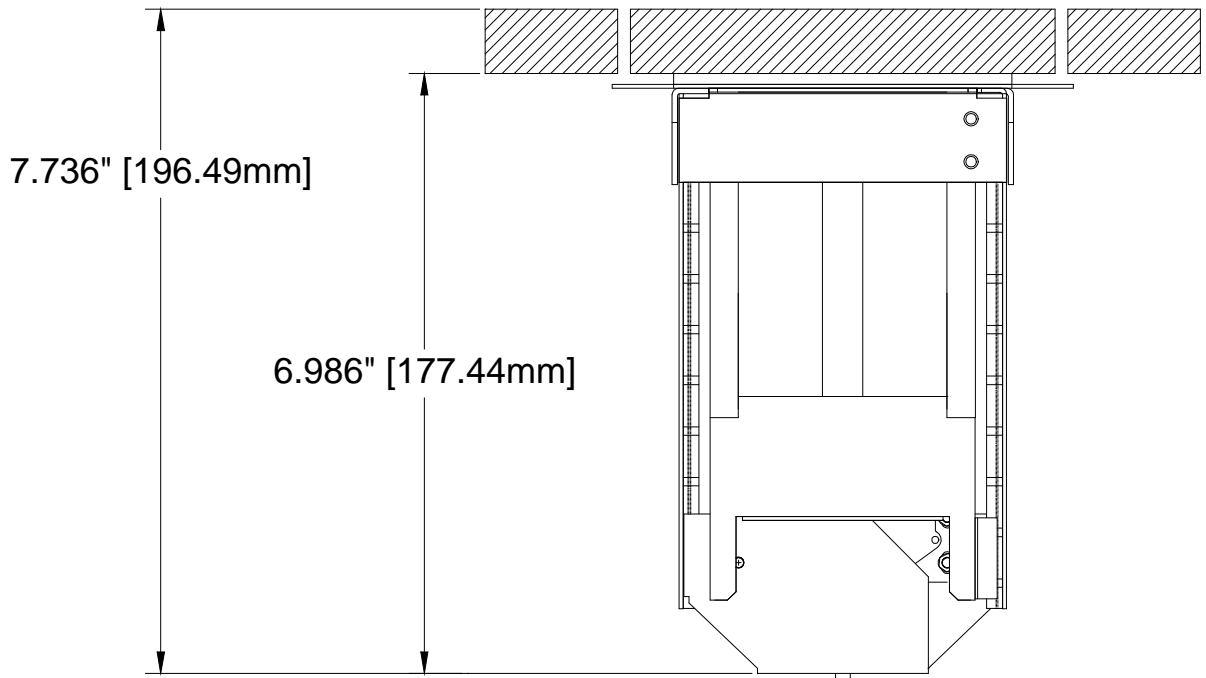

# TABLETOP SOLUTIONS

**DIAGRAM 4: FRONT VIEW DIMENSIONS**

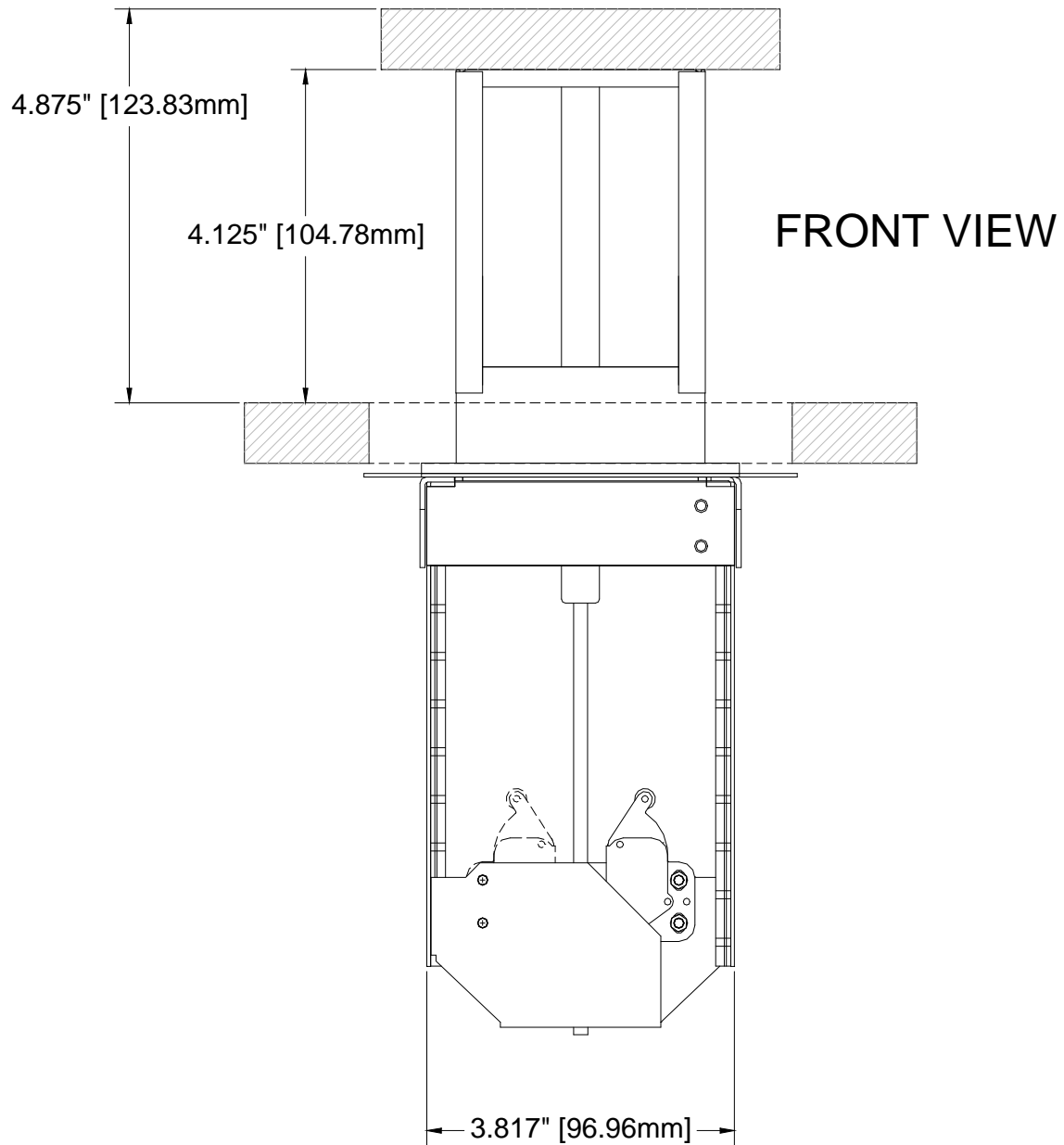

# TABLETOP SOLUTIONS

**DIAGRAM 5: SIDE VIEW DIMENSIONS**

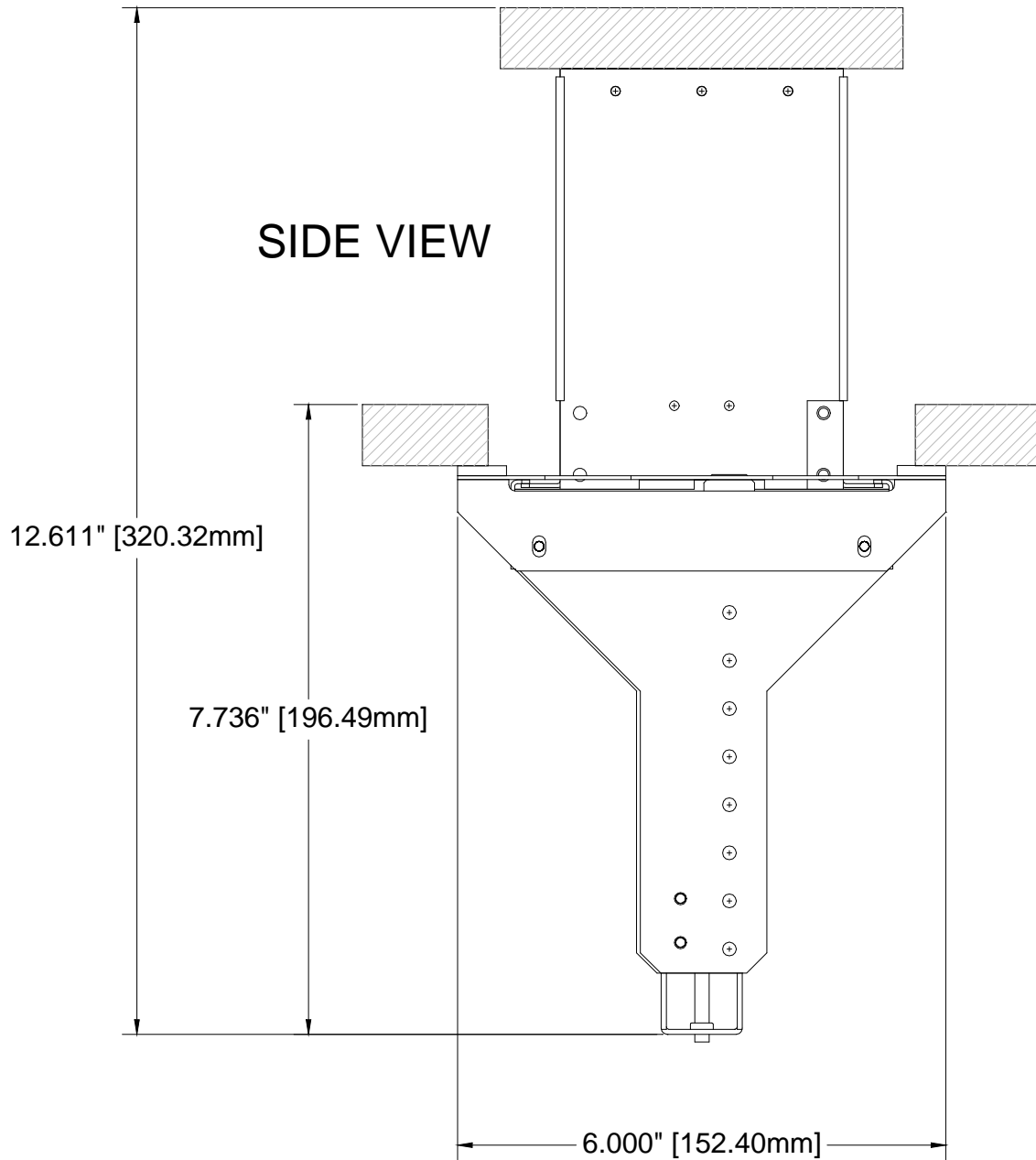

## INSTALLATION PROCEDURES 6

**Step 1.** Refer to the Altinex website, [www.altinex.com](http://www.altinex.com), to download the latest templates and instructions for tabletop cut-out requirements and installation instructions.

In order to do this, locate the **PNP415** or **PNP417** on the website and go to its detail page. The links to the templates, User's Guide, and more are on the left-hand side of the screen.

**Step 2.** Print all information applicable to the installation of the **PNP415/417**, including the templates and any detailed installation instructions.

**Step 3.** Cut an opening into the table's surface. This operation should be performed by experienced professionals in order to insure accuracy and to be aesthetically pleasing.

NOTE: Always confirm dimensions before cutting to insure that specifications have not changed.

**Step 4.** Install the **PNP415/417** into the table per the installation instructions provided on the website.

**Step 5.** Connect all **PNP415/417** cables to their appropriate sources and/or destinations. The **PNP415/417** is now ready for operation.

## OPERATION 7

### 7.1 OPENING AND CLOSING THE PNP415/417

The **PNP415/417** will open easily when the top is pressed down and then released.

When the **PNP415/417** is not in use, simply press the top down until it is level with the surface of the table and then release. The unit will remain hidden until needed again.

## 7.2 POWER/SIGNAL CONNECTIONS

Connect external devices to the appropriate connector on the **PNP415/417**. Remember, the devices plugged into the AC power connectors should not draw more than 5A AC.

## TROUBLESHOOTING GUIDE 8

The **PNP415/417** unit supplied was carefully tested and no problems were detected. However, we would like to offer the following suggestions:

- Please make sure that the highest quality network cables are used.
- Make sure that no cable or power cord is damaged or pinched. If there has been damage to the unit, do not use the **PNP415/417**. Please contact ALTINEX at (714) 990-2300 to have the unit repaired.

## ALTINEX POLICIES 9

### 9.1 LIMITED WARRANTY/RETURN POLICIES

Please also see the Altinex website at [www.altinex.com](http://www.altinex.com) for details the on warranty and return policies.

### 9.2 CONTACT INFORMATION

**ALTINEX, Inc.**

592 Apollo Street

Brea, CA 92821 USA

TEL: 714 990-2300

TOLL FREE: 1-800-ALTINEX

FAX: 714-990-3303

WEB: [www.altinex.com](http://www.altinex.com)

E-MAIL: [solutions@altinex.com](mailto:solutions@altinex.com)