



PAN-WAY METAL PMR5 & PMR7 SURFACE RACEWAY

INSTALLATION INSTRUCTIONS

© Panduit Corp. 2007

Printed In USA

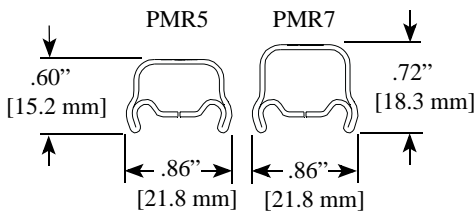

JOINT
COUPLING
PMR57JC

ALIGN HERE

MEASURE FOR NEXT
RACEWAY HERE

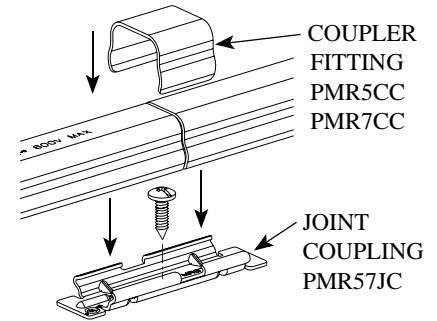
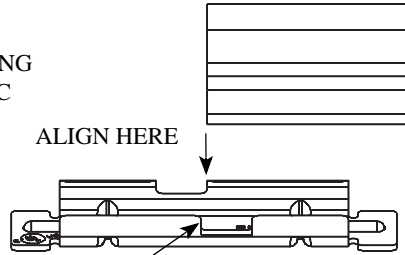

COUPLER
FITTING
PMR5CC
PMR7CC

JOINT
COUPLING
PMR57JC

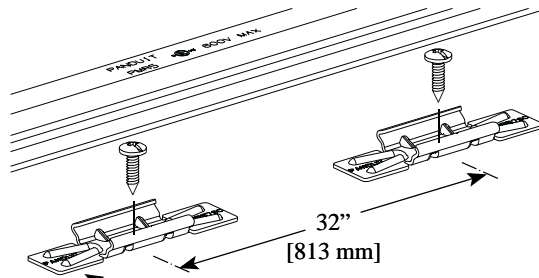
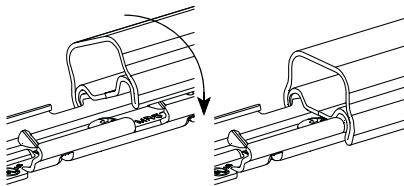

SUPPORTING CLIP
PMR57SC

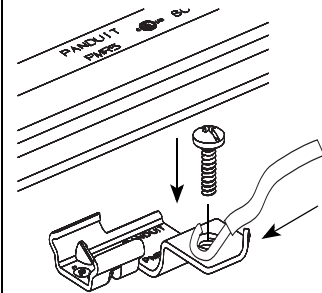

GROUND
CLAMP *
PMR57GC

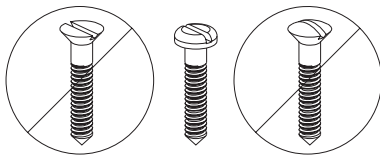

THE MOUNTING HARDWARE USED TO SECURE THE RACEWAY AND FITTINGS SHALL BE APPROPRIATE FOR THE MOUNTING SURFACE. USE #8 OR #10 PAN HEAD SCREWS.

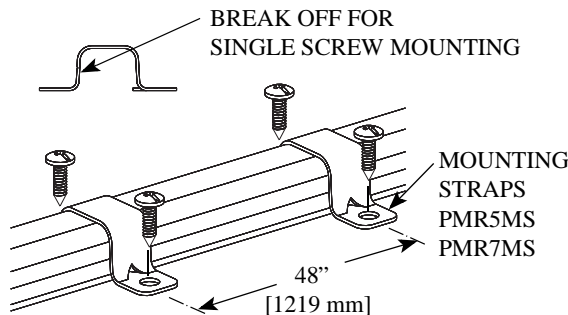

BREAK OFF FOR
SINGLE SCREW MOUNTING

MOUNTING
STRAPS
PMR5MS
PMR7MS

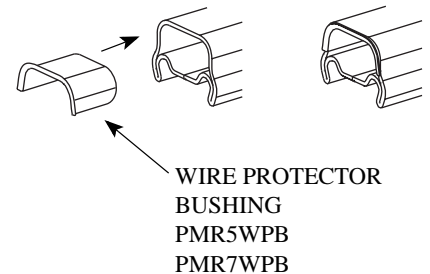

WIRE PROTECTOR
BUSHING
PMR5WPB
PMR7WPB

PANDUIT PAN-WAY METAL RACEWAY SYSTEMS CONFORM TO AND SHOULD BE INSTALLED AND PROPERLY GROUNDED IN COMPLIANCE WITH THE CURRENT NATIONAL ELECTRICAL CODE AND CANADIAN ELECTRICAL CODE.

ANY ELECTRICAL PRODUCT CAN CAUSE ELECTRICAL SHOCK OR FIRE HAZARD WHEN INSTALLED OR USED IMPROPERLY. ALL PANDUIT METAL RACEWAY PRODUCTS ARE UL LISTED TO U.S. AND CANADIAN SAFETY STANDARDS AND ARE DESIGNED FOR INDOOR USE ONLY, WHEN INSTALLED IN CONFORMANCE TO THE ABOVE CODES.

* DUE TO THE AGGRESSIVE LATCHING MECHANISM FOR THE GROUND CLAMP, REMOVAL OF THIS PART AFTER INSTALLATION WILL REDUCE GROUNDING BOND EFFICIENCY. IF REPOSITION IS NECESSARY, REMOVE THE GROUND CLAMP AND DISCARD. INSTALL A NEW GROUND CLAMP IN THE DESIRED LOCATION.