

THIS COPY IS PROVIDED ON A RESTRICTED BASIS AND IS NOT TO BE USED IN ANY WAY DETRIMENTAL TO THE INTERESTS OF PANDUIT CORP.

PANDUIT PART NO.	PACKAGE QTY.	MAX BUNDLE DIA	"LENGTH" ±.3 [ 7 ]
MLTFC2H-LP316	50	2" [ 51 ]	7.9"[ 201 ]
Ⓐ MLTFC2.7H-LP316	50	2.7" [ 69 ]	10.15"[ 258 ]
MLTFC4H-LP316	50	4" [ 102 ]	14.3"[ 362 ]
MLTFC6H-LP316	50	6" [ 152 ]	20.5"[ 521 ]
MLTFC8H-LP316	50	8" [ 203 ]	26.8"[ 679 ]

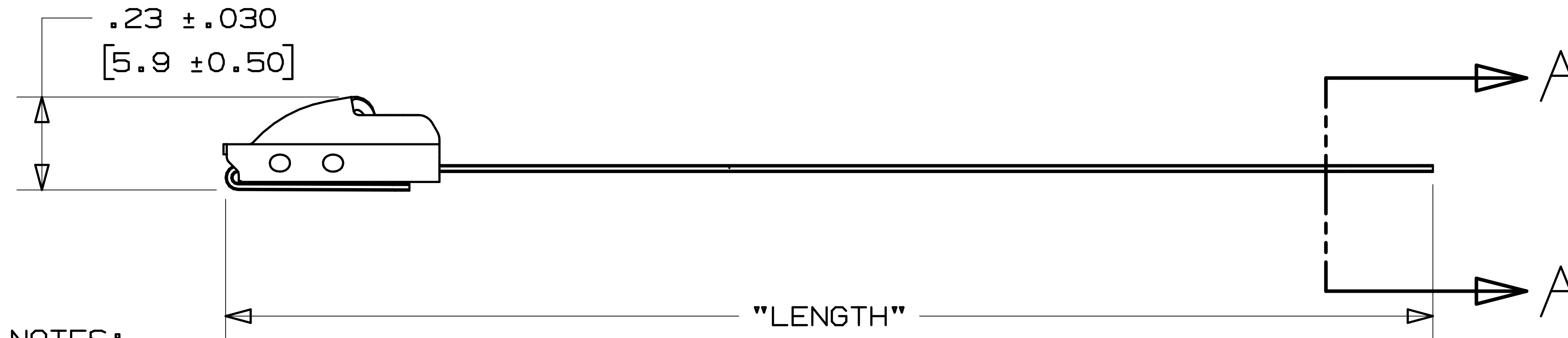
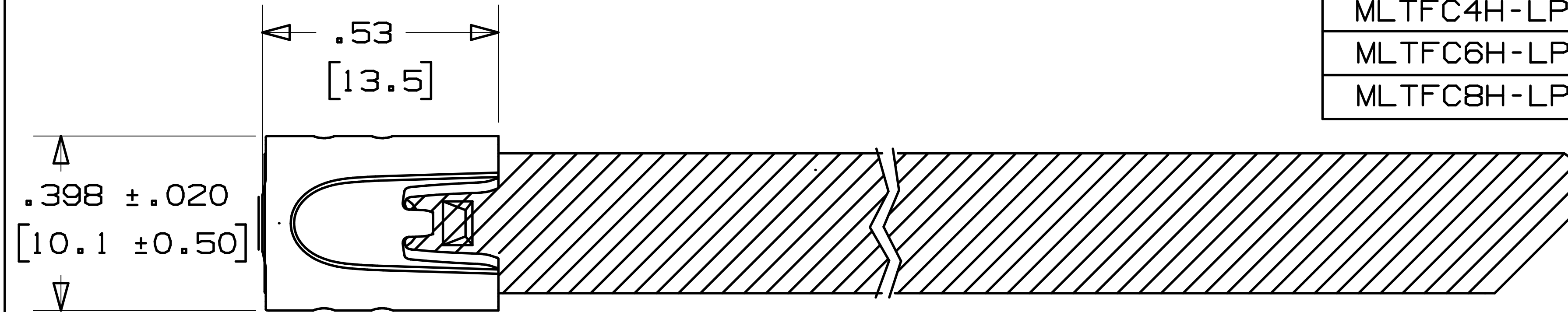

NOTES:

- 1.) APPLICATION TOOLS - GS4MT, PPTMT, ST2MT, HTMT OR ST3MT
- 2.) MINIMUM LOOP TENSILE STRENGTH - 250 LBS. (1112 NEWTONS) WHEN TESTED ON A 1.5" MANDREL.
- 3.) [ ] DENOTES DIMENSION IN MILLIMETERS
- 4.) TOLERANCES:  
 .XXX = ±.010 [ .25 ]  
 .XX = ±.02 [ .5 ]  
 .X = ±.03 [ .8 ]  
 ANGLES = ±2°
- 5.) MATERIAL: 316 STAINLESS STEEL
- 6.) COATING - POLYESTER  
 COATING THICKNESS: .002 MIN./ .005 MAX. PER SIDE

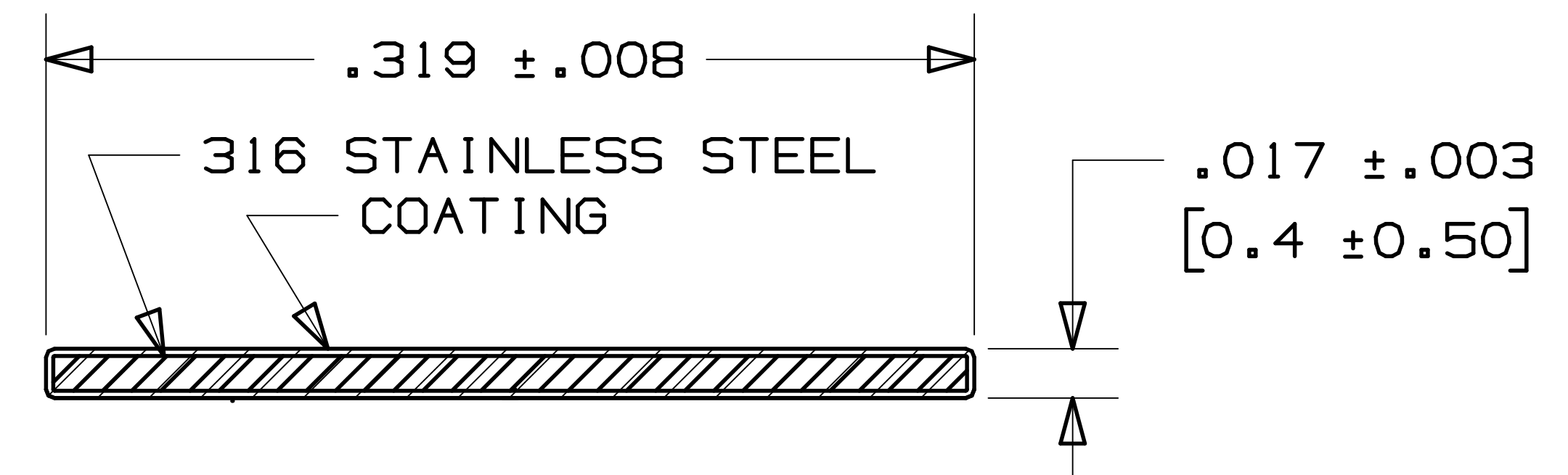

SECTION A - A  
SCALE: 10x

S41193\_02

REV	DATE	BY	CHK	DESCRIPTION	ECN #	PM	CUST	DRAWN BY	CHK'D	SCALE	DRAWING NO.
02	11/05	JMMR	EJD	Ⓐ ADDED MLTFC2.7H-LP316 TO TABLE	SS00112	---	---	<b>PANDUIT</b> CORP.      TINLEY PARK, ILLINOIS METAL LOCKING TIE - COATED HEAVY SERIES 316 STAINLESS STEEL (CUSTOMER DRAWING)			
01	3/05	JAMB	PAB	DRAWING REVISED TO REFLECT CURRENT COATED HEAVY SERIES PRODUCT	12501	CCH	JJB				
00	11/04	JAMB	PAB	RELEASED	12169	CCH	JJB				
								JAMB	PAB	2x	S41193