

INSTRUCTION MANUAL

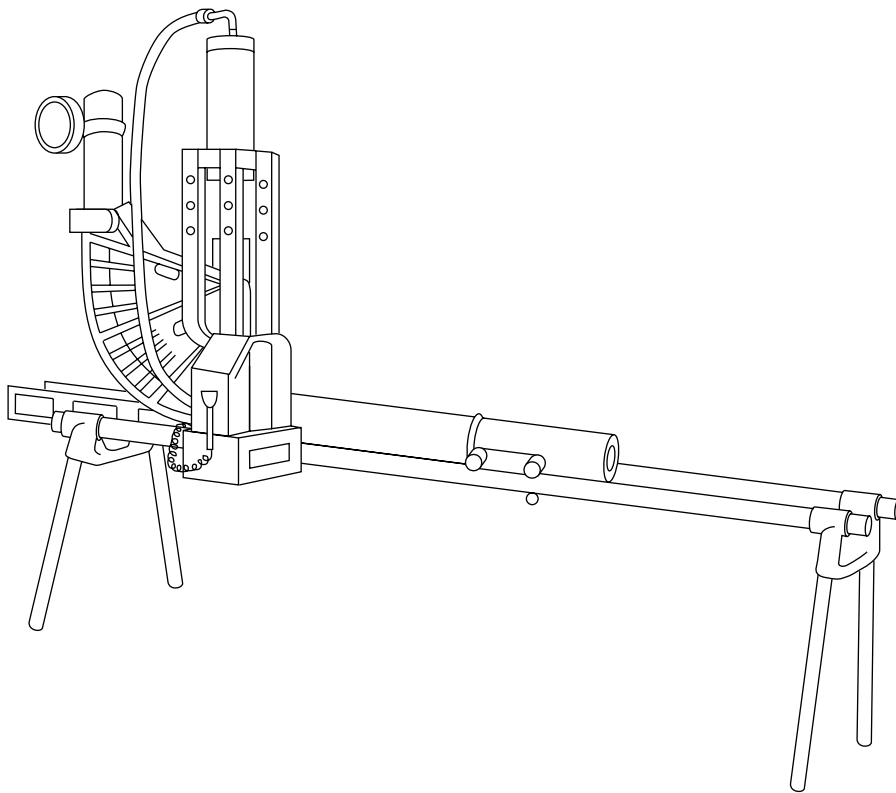

GREENLEE®

A Textron Company



881 and 881CT Cam Track® Hydraulic Benders and 1813 Bending Table



Read and understand all of the instructions and safety information in this manual before operating or servicing this tool.

Table of Contents

Description	2
Safety	2
Purpose of this Manual	2
Important Safety Instructions	3-4
Identification—Major Components, 881 and 881CT Bender	5
Assembly and Operation Instructions	6-21
881 and 881CT—Floor Operation	6-9
Identification—Major Components, 1813 Bending Table	10
881 and 881CT with 1813 Bending Table	11-21
Glossary of Bending Terms with Illustrations	22
Laying Out One-Shot 90° Bends	23
Table 2—Deduct, Stub Dimensions, Minimum Distance from End of Conduit	23
Table 3—Ram Travel	24
Laying Out Two-Shot 90° Bends for 3-1/2" and 4" Conduit (881 only)	25
Laying Out Bends	26-28
Stubs	26
Offsets	26-27
Saddles	27-28
U-Bends	28
Special Bending Information Chart	29-32
Troubleshooting	33-34
Identification—Major Components, 881 and 881CT Bender	35
Parts List—881 and 881CT	36
Shoe Groups	37-39
Exploded View—Ram	40
Parts List—Ram	41
Exploded View—1813 Bending Table	42
Parts List—1813 Bending Table	43-44

Description

The 881 and 881CT Cam Track® Hydraulic Benders are intended to bend rigid conduit, IMC (intermediate metallic conduit), EMT (electrical metallic conduit) and Schedule 40 pipe. Bending shoes, follow bars and saddles are available for bending 2-1/2" through 4" conduit or pipe.

The bender is to be coupled to any Greenlee hydraulic pump capable of developing 10,000 psi with a usable oil volume of 6 quarts or more. Suggested pumps include the following models:

Electric Pump (120 volt)	960 SAPS	980
Electric Pump (220 Volt)	980-22FS	980-22PS

Safety

Safety is essential in the use and maintenance of Greenlee tools and equipment. This instruction manual and any decals on the tool provide information for avoiding hazards and unsafe practices related to the use of this tool. Observe all of the safety information provided.

Purpose of this Manual

This instruction manual is intended to familiarize operators and maintenance personnel with the safe operation and maintenance procedures for the Greenlee:

881 and 881CT Cam Track® Hydraulic Benders

Keep this manual available to all personnel.

Replacement manuals are available upon request at no charge.

All specifications are nominal and may change as design improvements occur. Greenlee Textron shall not be liable for damages resulting from misapplication or misuse of its products.

Cam Track is a registered trademark of Greenlee Textron.

KEEP THIS MANUAL



IMPORTANT SAFETY INFORMATION



SAFETY ALERT SYMBOL

This symbol is used to call your attention to hazards or unsafe practices which could result in an injury or property damage. The signal word, defined below, indicates the severity of the hazard. The message after the signal word provides information for preventing or avoiding the hazard.

⚠ DANGER

Immediate hazards which, if not avoided, **WILL** result in severe injury or death.

⚠ WARNING

Hazards which, if not avoided, **COULD** result in severe injury or death.

⚠ CAUTION

Hazards or unsafe practices which, if not avoided, **MAY** result in injury or property damage.

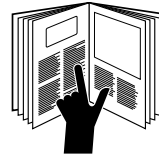

⚠ WARNING

Read and understand all of the instructions and safety information in this manual before operating or servicing this tool.

Failure to observe this warning can result in severe injury or death.

⚠ WARNING

Use only Greenlee shoes and components when operating this bender. Other manufacturers' shoes and components may fail during operation, propelling broken parts with great force.

Failure to observe this warning can result in severe injury or death.

IMPORTANT SAFETY INFORMATION

	⚠ WARNING
	Pinch points. Keep hands away from bending shoe, follow bar, saddle, conduit, and other moving parts when bender is in use. Failure to keep hands away from these areas can result in serious injury.

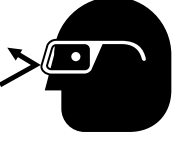
	⚠ WARNING
	Wear eye protection when operating the bender. Failure to wear eye protection can result in serious eye injury from flying debris or hydraulic oil.

⚠ WARNING
Do not operate while wearing loose clothing. Loose clothing could get caught in moving parts. Failure to observe this warning could result in severe injury.

⚠ WARNING
Do not stand in direct line with the hydraulic ram. A component failure could propel parts with great force, striking nearby personnel. Failure to observe this warning could result in severe injury or death.

⚠ WARNING
Do not stand in direct line with the follow bar. A component failure could propel the follow bar with great force, striking nearby personnel. Failure to observe this warning could result in severe injury or death.

⚠ CAUTION
Inspect the bender, pump, and hose before each use. Replace damaged, worn, or missing parts with Greenlee replacement parts; a damaged or worn component may fail and strike nearby personnel.

⚠ CAUTION
Some bender parts and accessories are heavy and require more than one person to lift and assemble. Failure to observe this precaution could result in injury or property damage.

IMPORTANT
Make sure all hose fittings are properly seated before starting the bend. Incomplete connections may not allow the ram to retract after the bend is complete.

IMPORTANT
Follow the instructions and safety information supplied with your hydraulic pump.

Identification—Major Components

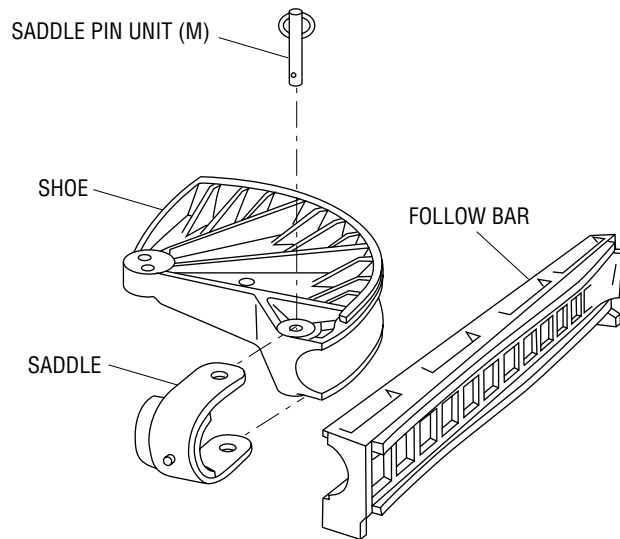
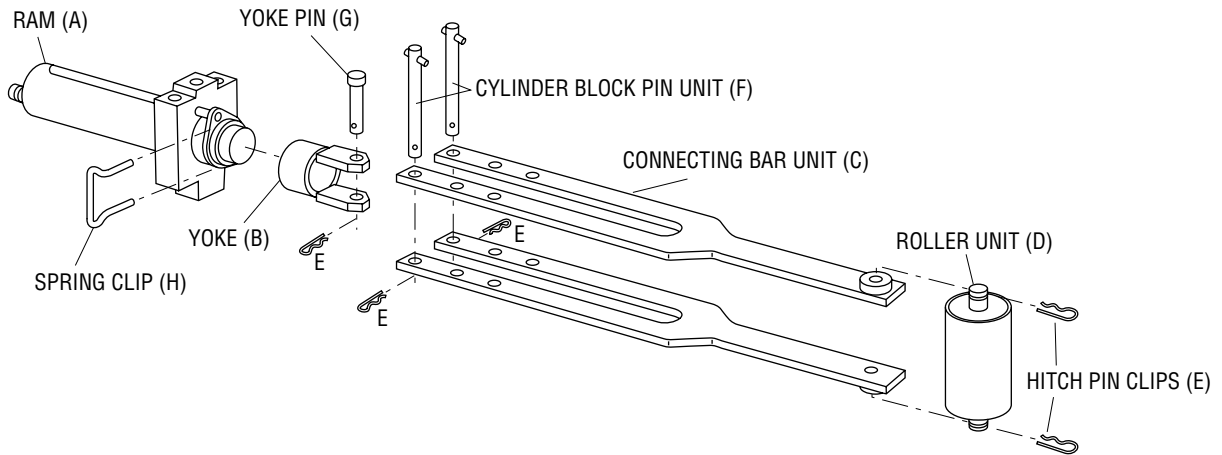

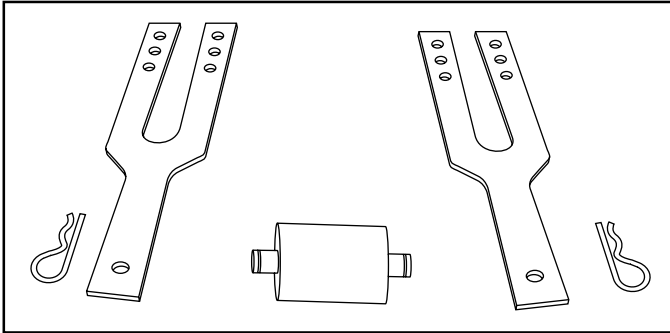
Assembly and Operation Instructions**881 and 881CT—Floor Operation (refer to Identification—Major Components)**

1. Lay out the connecting bars (C), roller unit (D), and two hitch pin clips (E).

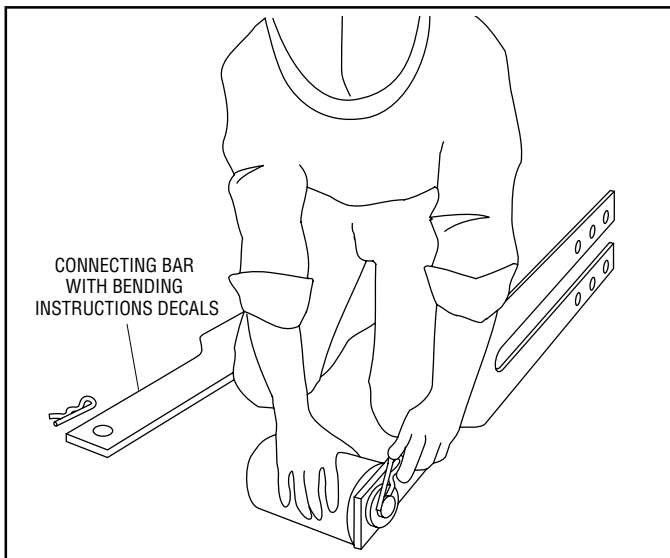

2. Attach the roller unit to one of the connecting bars with a hitch pin clip, as shown.

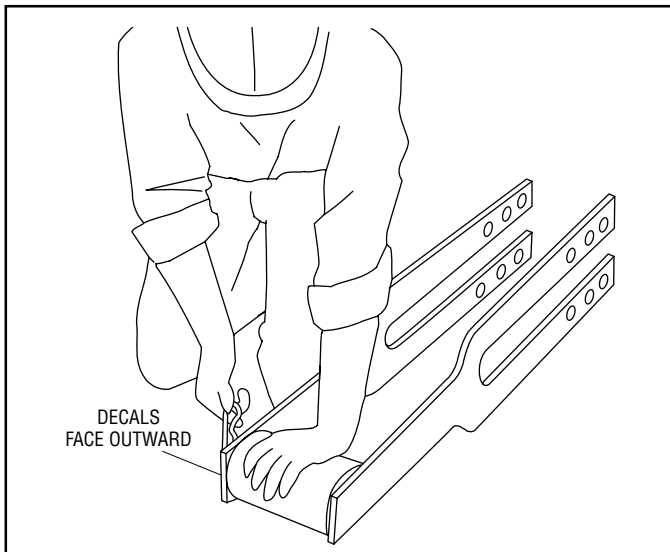

3. Repeat Step 2 for the other connecting bar.

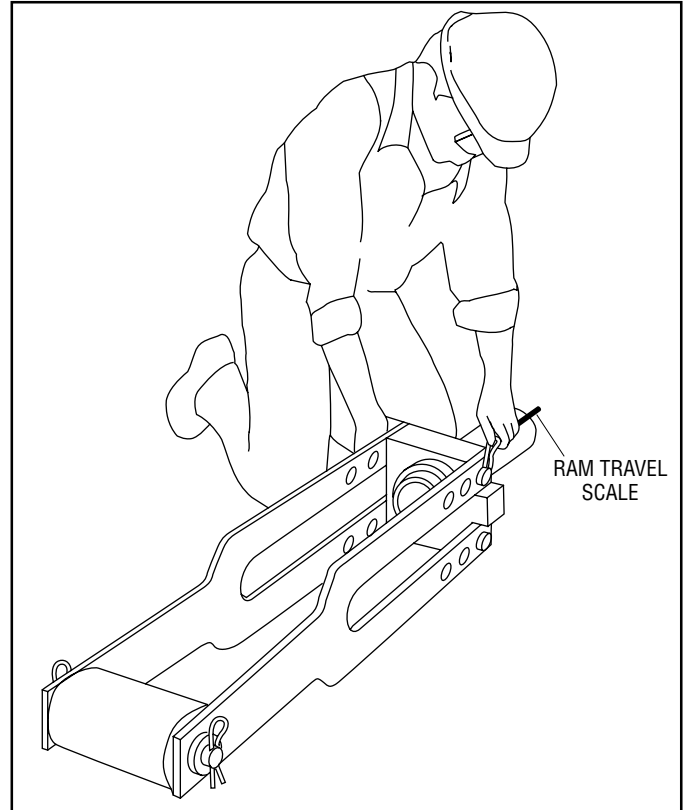

4. Position the ram and cylinder block so that, from the operator's point of view, the ram scale is up and to the left of the ram.

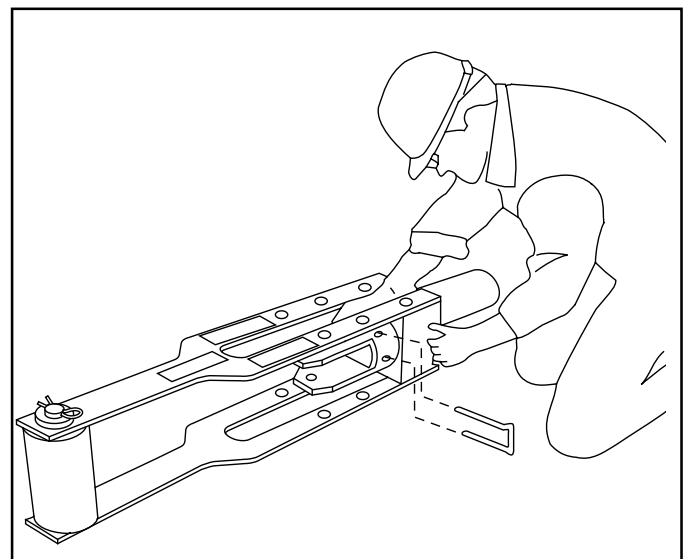

5. Attach the yoke (B) to the ram with the spring clip (H).

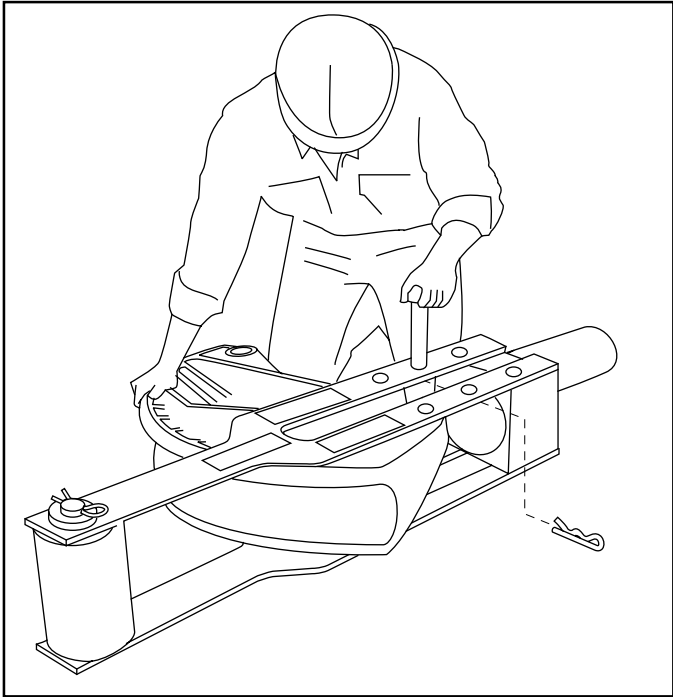
Assembly and Operation Instructions**881 and 881CT—Floor Operation (cont'd)**

6. Select the shoe for the size of conduit to be bent. Insert the shoe with the shoe size marking facing up. Align either the EMT or Rigid/IMC hole with the yoke and insert the yoke pin (G). Secure the yoke pin with a hitch pin clip (E).

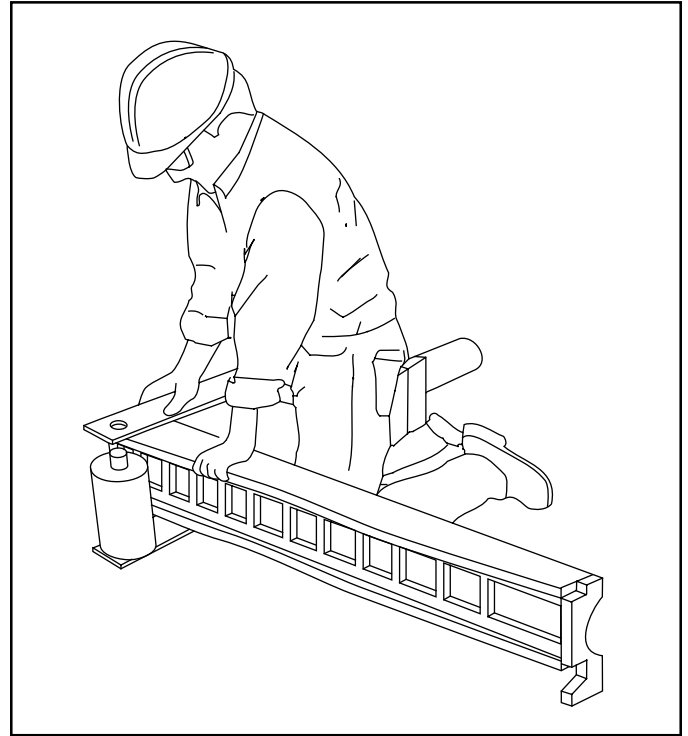

8. Lift the connecting bar and insert the follow bar.
Note: Insert the end marked START.

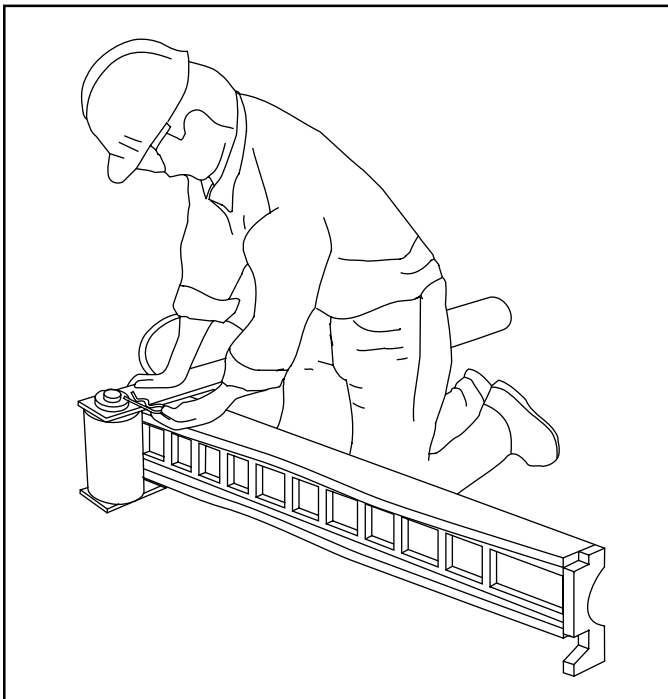

7. Remove one hitch pin clip from the roller shaft.

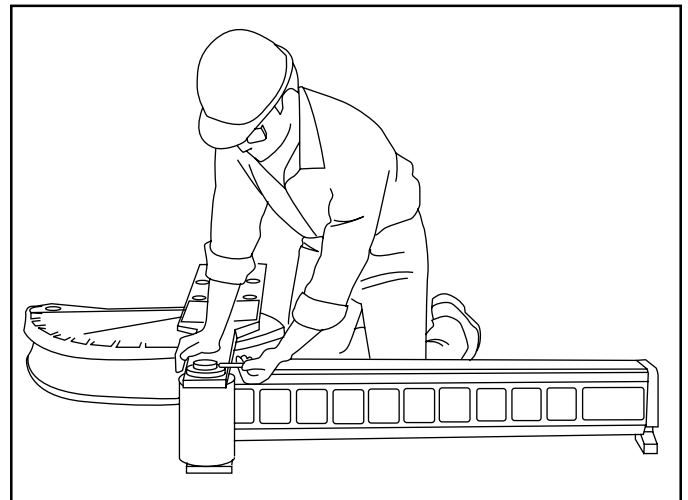

9. Reinsert the hitch pin clip into the roller shaft.

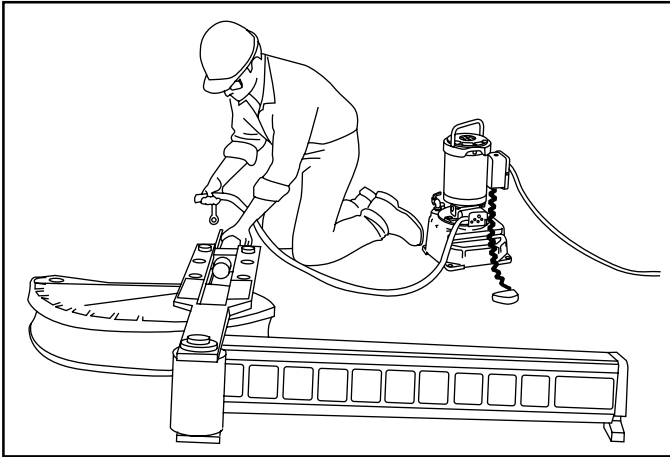
Assembly and Operation Instructions**881 and 881CT—Floor Operation (cont'd)**

10. Attach the hose (L) to the pump and ram.

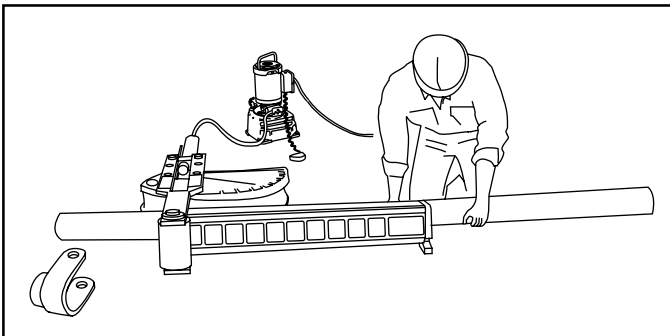

11. Make sure the shoe and follow bar grooves are clean. Insert the conduit into the bender.

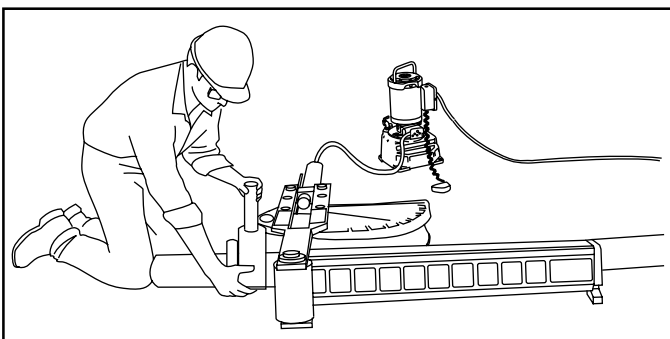

12. Set the conduit into the groove of the shoe. Rotate the shoe as necessary to align the saddle with the shoe. Position the saddle so the saddle insert is toward the operator, as shown. Attach the saddle to the shoe with the saddle pin unit (M); secure the pin unit with the hitch pin clip (E).

Note: Align the bending mark on the conduit with the outside edge of the saddle insert.

IMPORTANT

Follow the instructions and safety information supplied with your hydraulic pump.

The instructions provided here apply to Greenlee 960 (shown in the illustrations) and 980 (not shown) hydraulic pumps only.

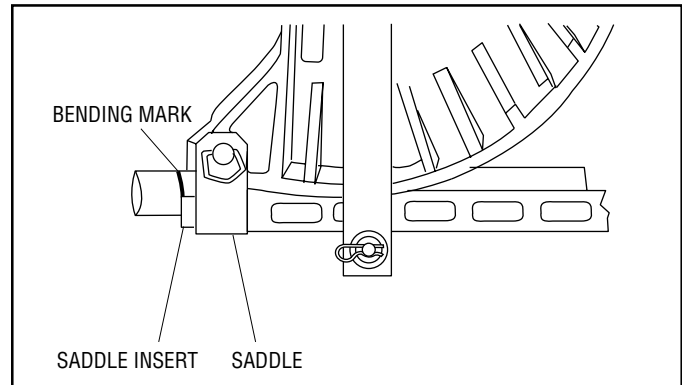

13. Rotate the pump control lever counterclockwise. Activate the hydraulic pump until the shoe just contacts the conduit. Check that the saddle and follow bar are snug. Be sure that the follow bar contacts the saddle. Be sure that the bending mark on the conduit is aligned with the front edge of the saddle insert. Calibrate the bender (see Calibrate the Bender Before Bending under Table 3—Ram Travel).

Activate the hydraulic pump to begin the bend.

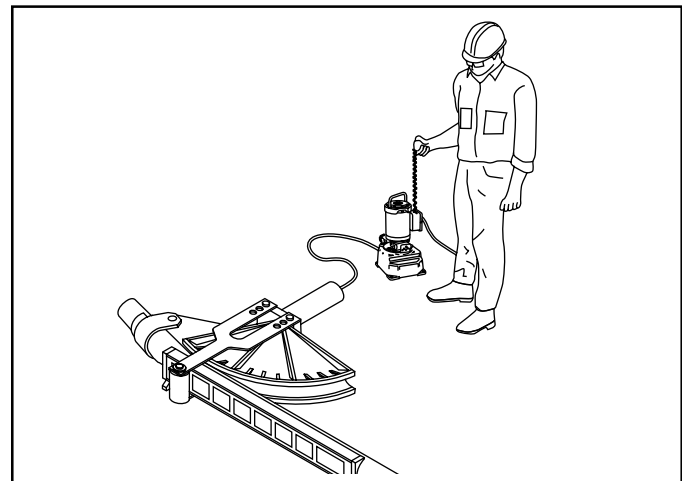

14. 10° of bend.

Assembly and Operation Instructions

881 and 881CT—Floor Operation (cont'd)

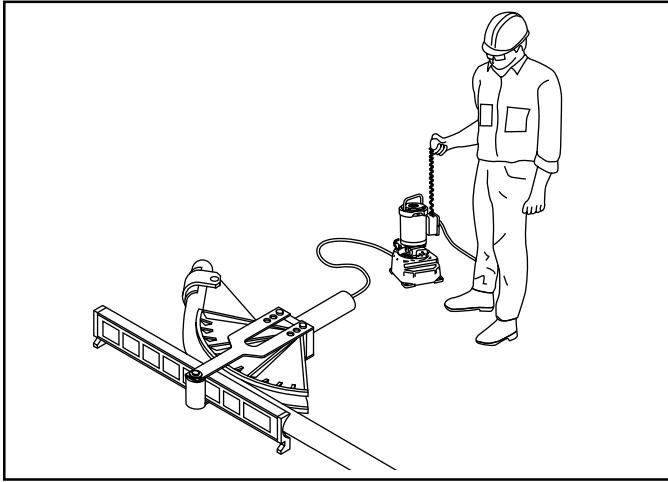

15. 45° of bend.

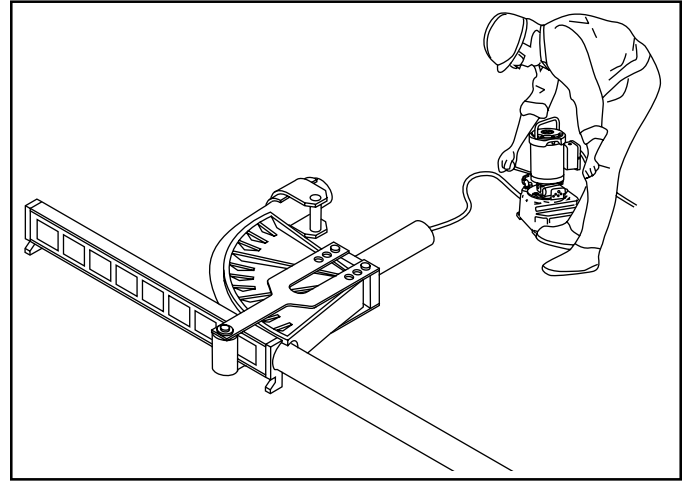

18. Release the hydraulic pressure. The ram will retract.

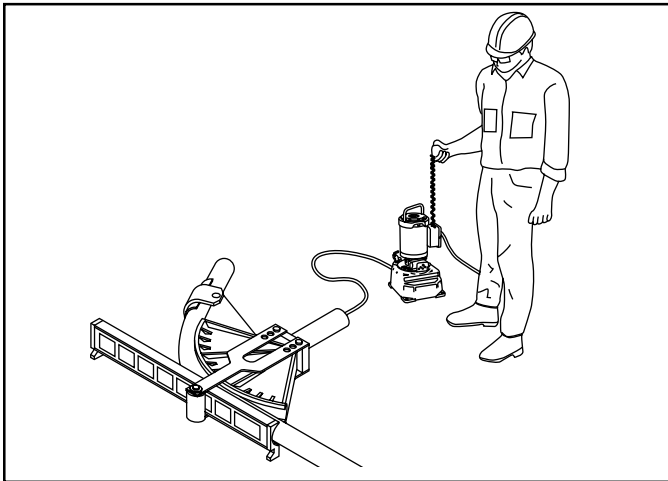

16. 60° of bend.

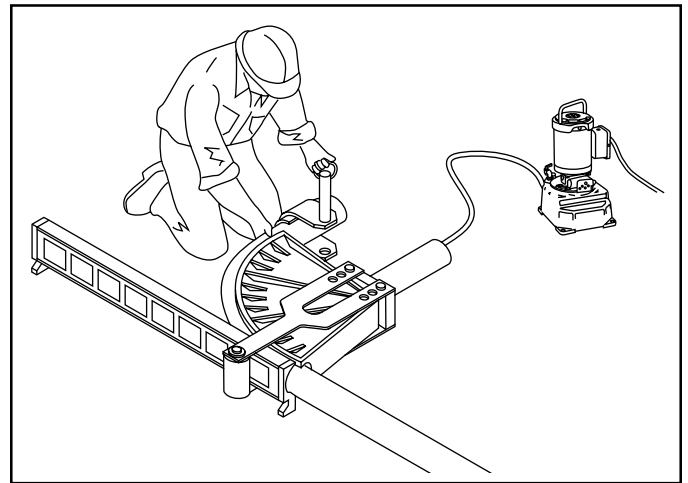

19. Remove the saddle pin.

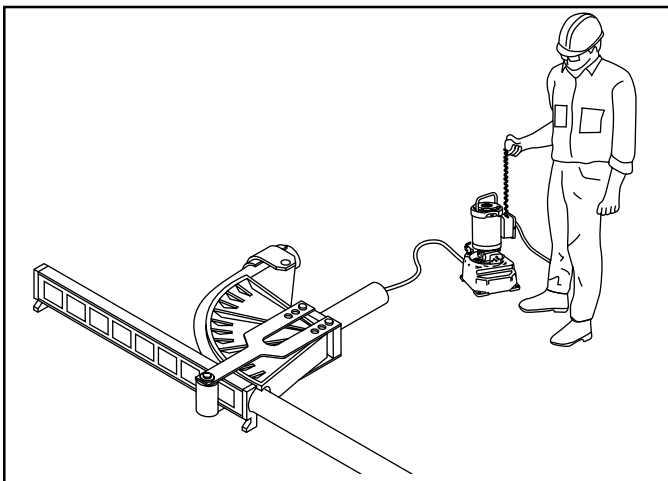

17. 90° of bend.

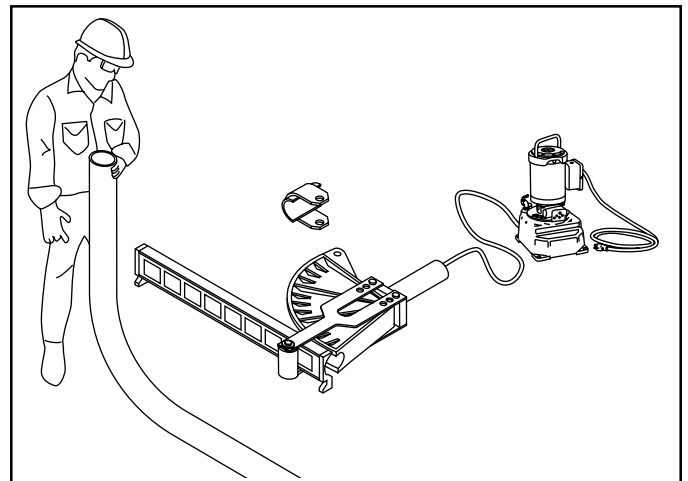

20. The 90° bend is complete.

Identification—Major Components

881 and 881CT Cam Track® Hydraulic Bender and 1813 Bending Table

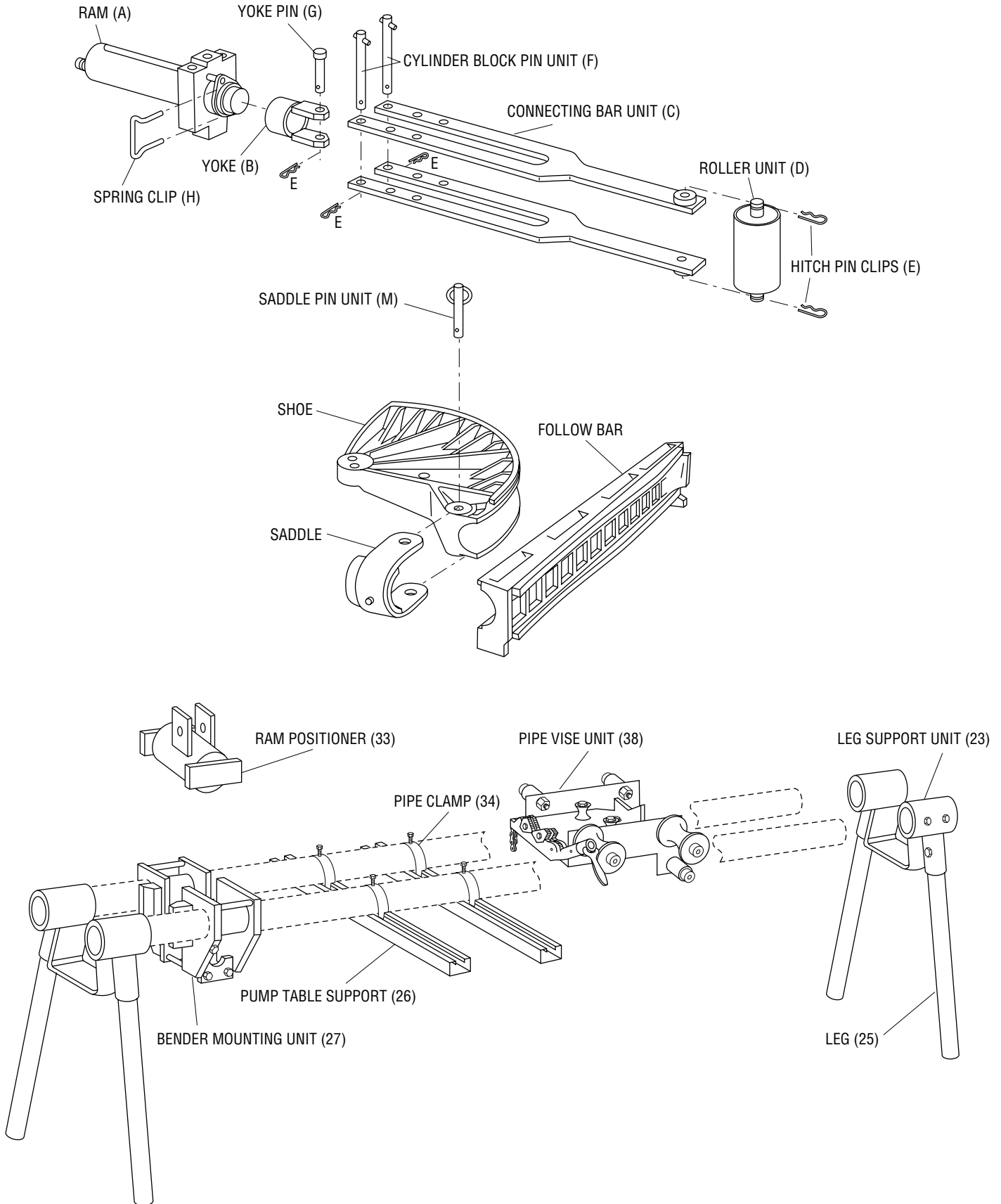

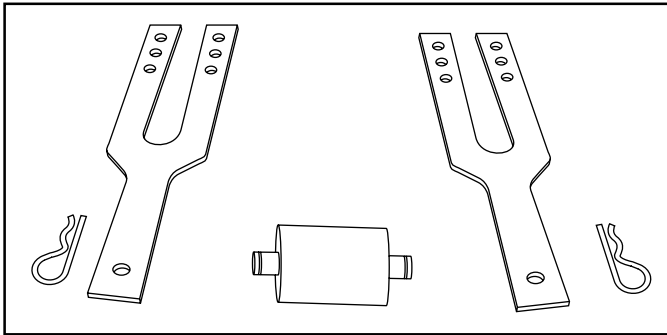
Assembly and Operation Instructions**881 and 881CT with 1813 Bending Table (refer to Identification—Major Components)**

1. Lay out the connecting bars (C), roller unit (D), and two hitch pin clips (E).

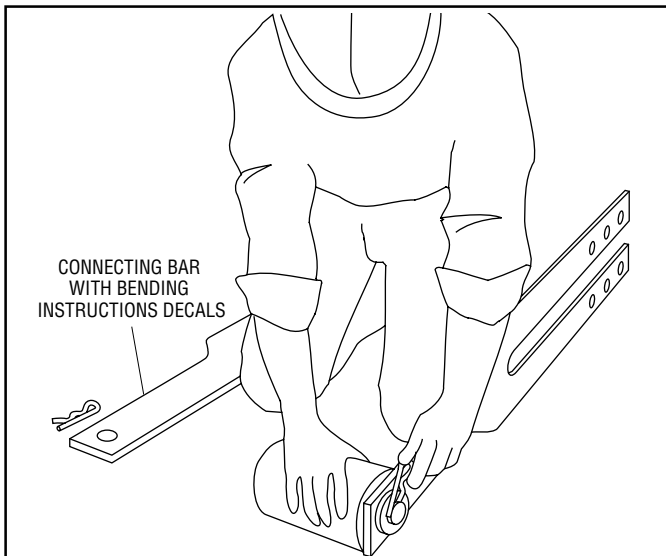

2. Attach the roller unit to one of the connecting bars with a hitch pin clip, as shown.

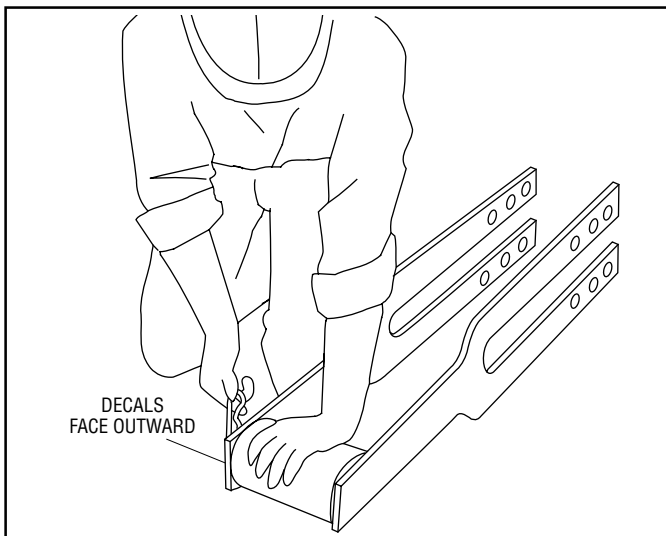

3. Repeat Step 2 for the other connecting bar.



4. Insert 29" leg (25) into leg support unit (23). Tighten the cap screw (24). Repeat for the other three legs.

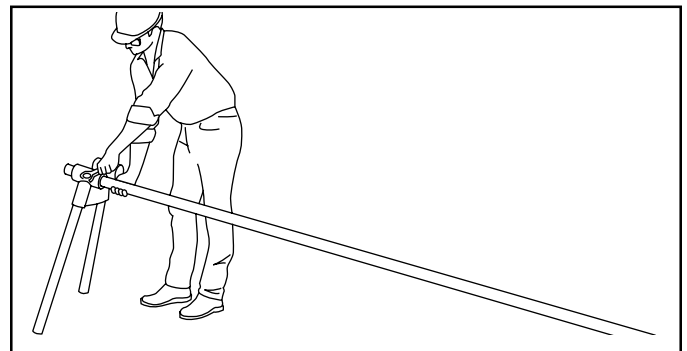

5. Insert two 10-foot lengths of IMC or rigid conduit into the leg support unit (23). Tighten four cap screws (24).
Note: These lengths of conduit are not furnished with the 1813 Bending Table.

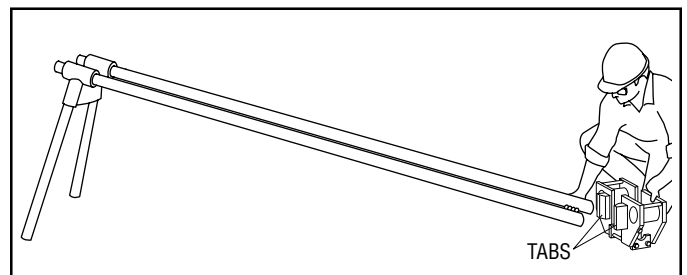

6. Position the bender mounting unit (27) as shown, and slide it, tabs first, onto the two 10-foot conduits.

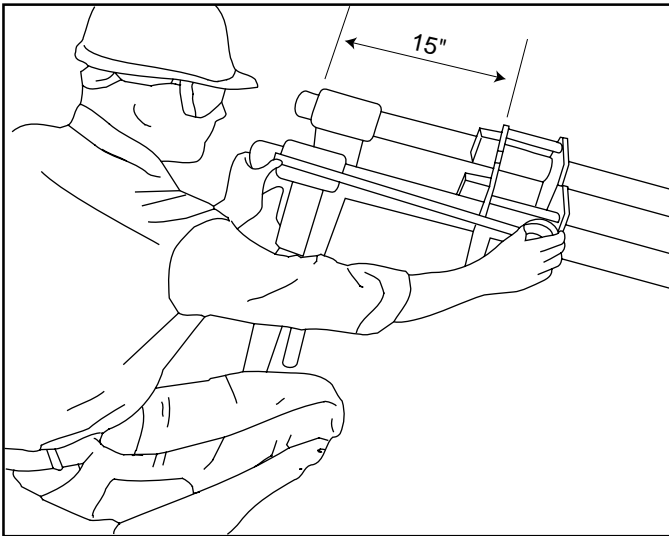
Assembly and Operation Instructions**881 and 881CT with 1813 Bending Table (cont'd)**

7. Position the bender mounting unit 15" from the leg support unit. Tighten the two bender mounting unit screws (28).

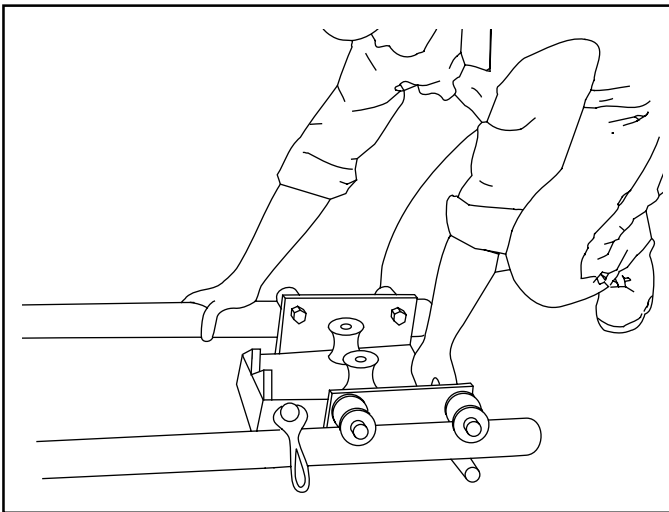

8. Slide the pipe vise unit (38) onto the two 10-foot conduits, as shown.

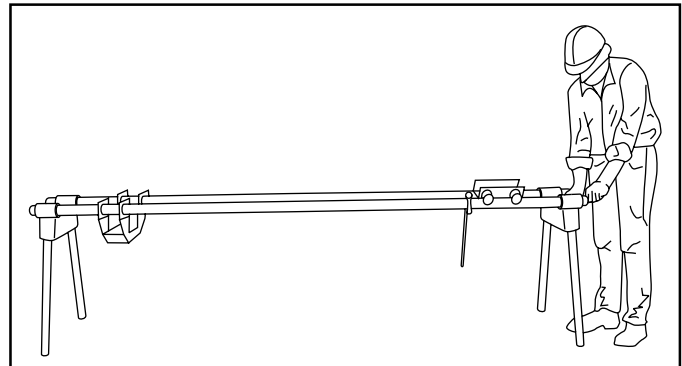

9. Attach the second leg support unit (23) to the 10-foot conduits. Tighten the four screws (24).

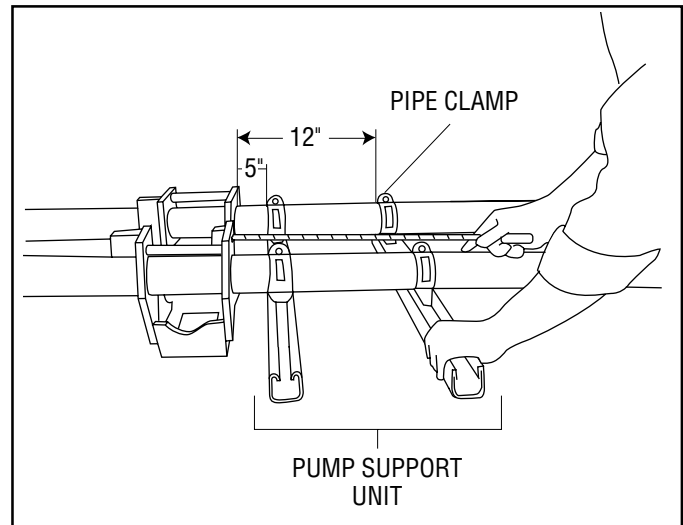

10. Hang the two pipe clamps (34) over each of the 10-foot conduits. Set the pipe clamps 5" and 12" from the bender mounting unit. Mount the pump supports (26) onto the clamps. Do not tighten the clamps.

Assembly and Operation Instructions

881 and 881CT with 1813 Bending Table (cont'd)

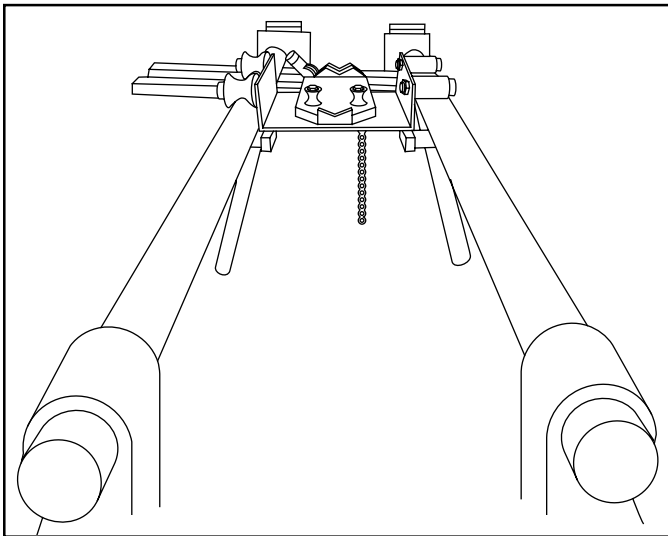
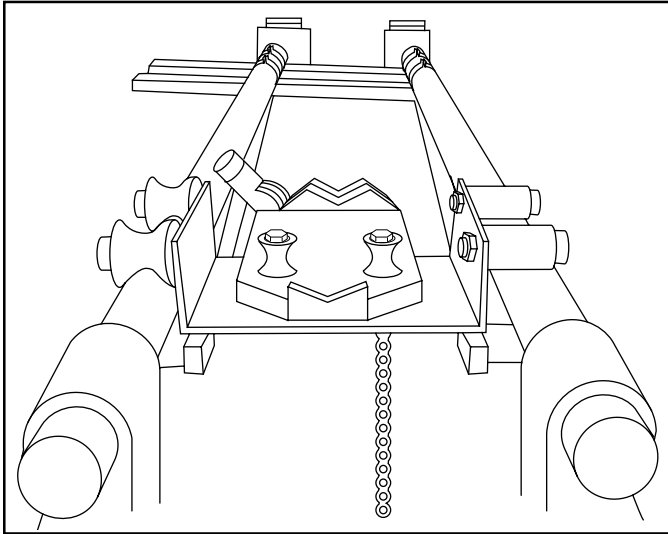

11 and 12. Level the table at both ends.

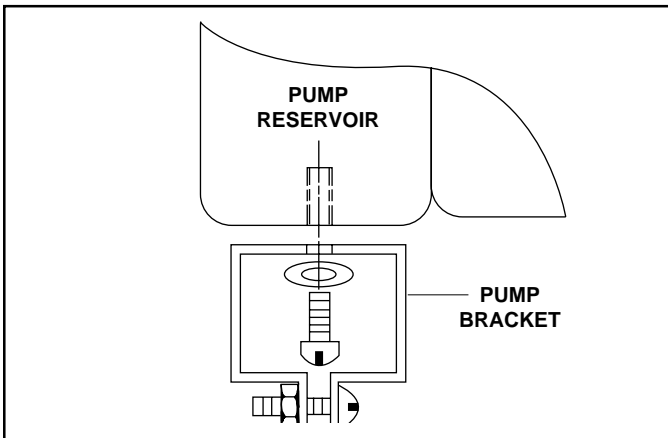

13. Remove the rubber feet/casters from the pump. Attach the pump bracket (64) to the pump with the pump bracket mounting hardware (40-43). See illustration.

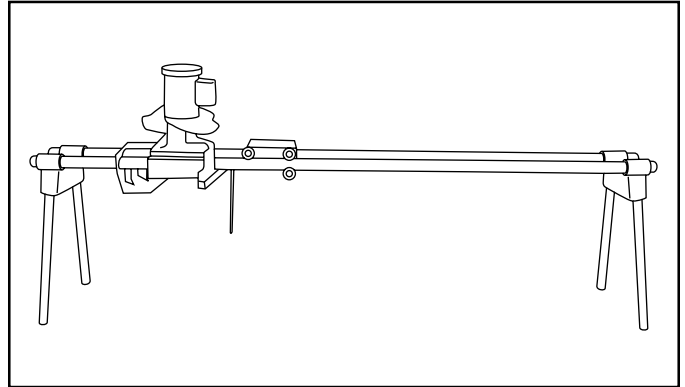

14. Slide the pump onto the pump supports. Tighten the screws on the lower sides of the pump brackets to secure the pump. Verify that the pump supports are 5" and 12" from the bender mounting unit. Tighten the pipe clamp screws.

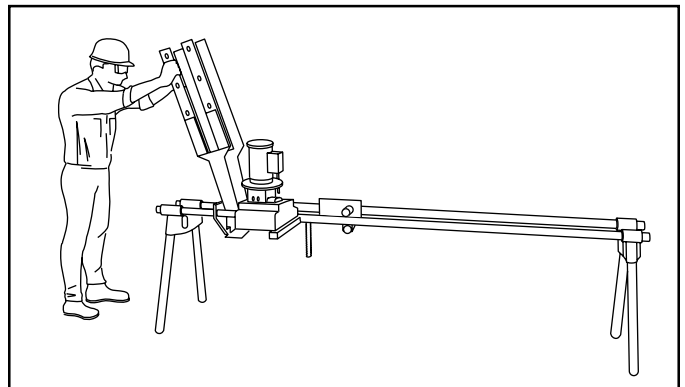
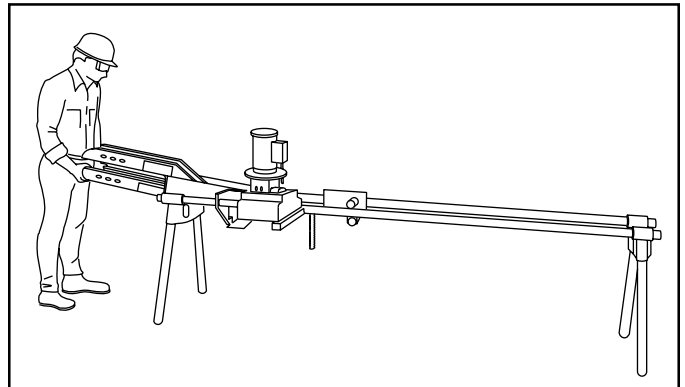

15 and 16. Load the connecting bar and roller unit into the bender mounting unit.

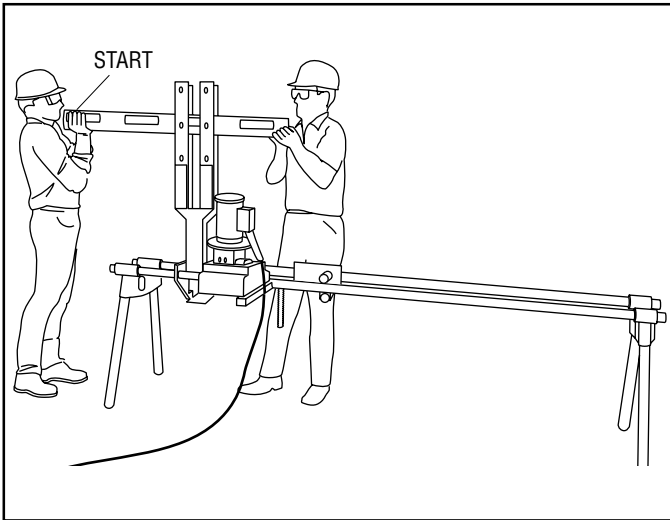
Assembly and Operation Instructions**881 and 881CT with 1813 Bending Table (cont'd)**

17. Insert the follow bar into the bender with the end marked **START**, as shown.

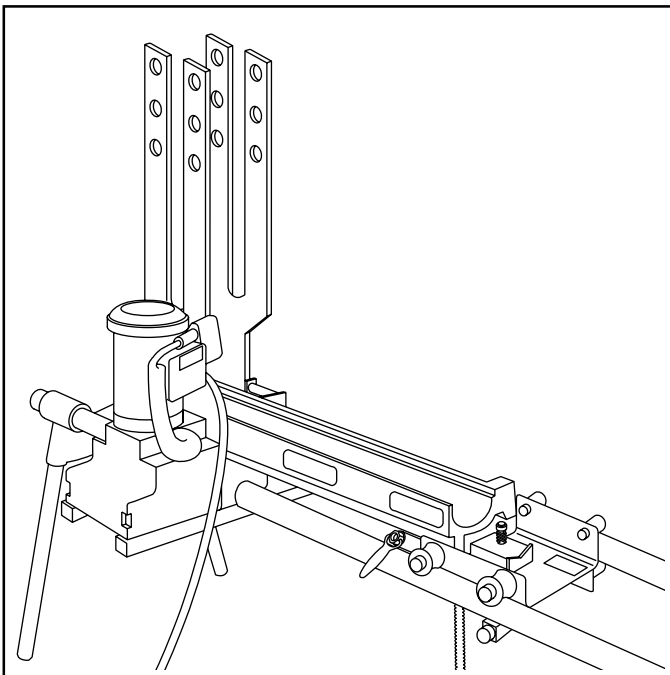

18. Support the rear of the follow bar on the pipe vise unit.

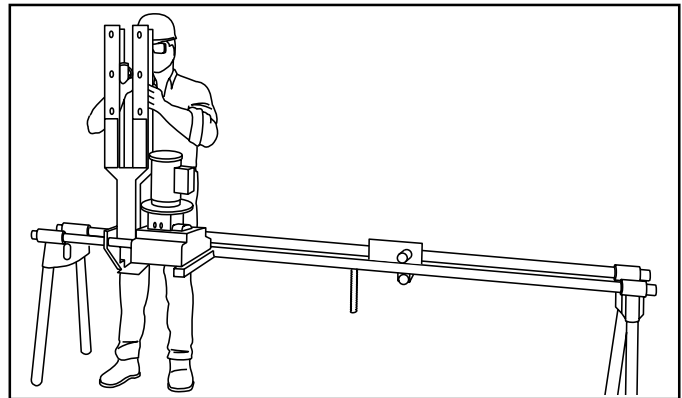
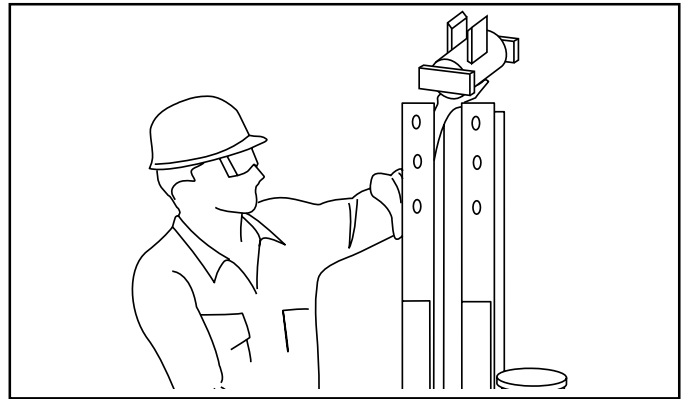

19 and 20. Insert the ram positioner (33).

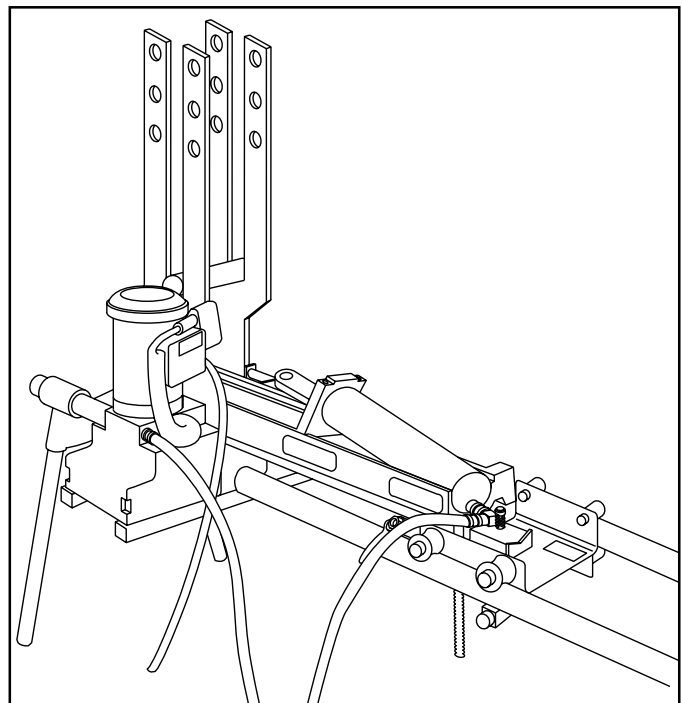

21. Attach the hydraulic fitting unit (29) to the ram, and connect the hose to the fitting unit. Set the cylinder and yoke unit on the follow bar. Rotate the pump control lever counterclockwise.

Assembly and Operation Instructions

881 and 881CT with 1813 Bending Table (cont'd)

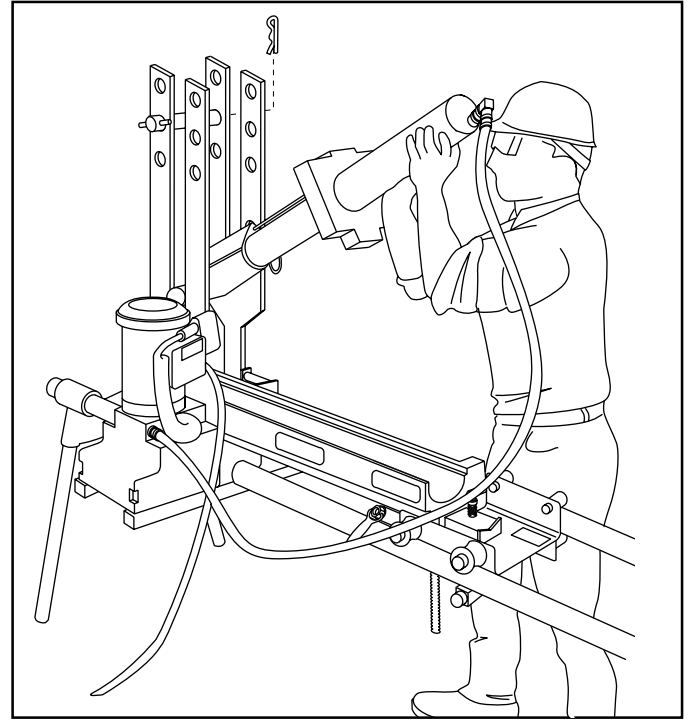
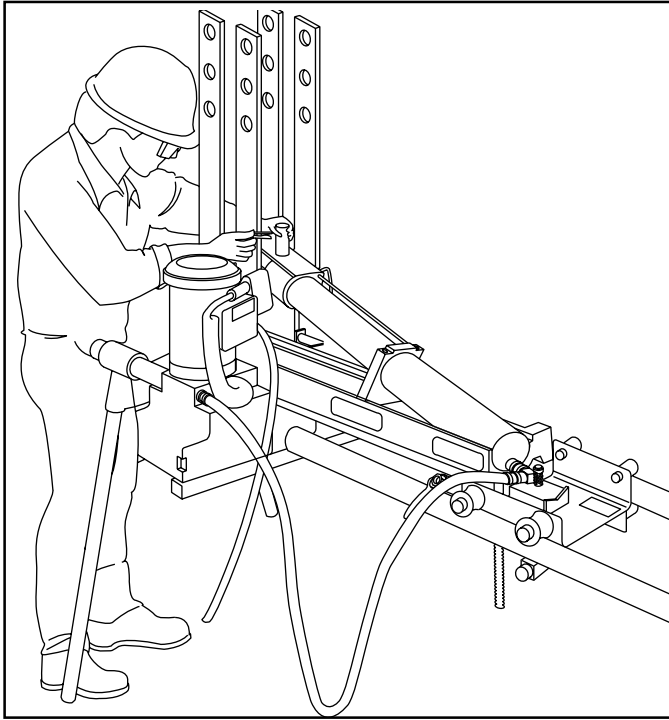

22. Activate the hydraulic pump to extend the ram approximately 14 inches. **DO NOT OVER EXTEND.** Attach the yoke to the ram positioner with the yoke pin (G). Secure the yoke pin with a hitch pin clip (E).

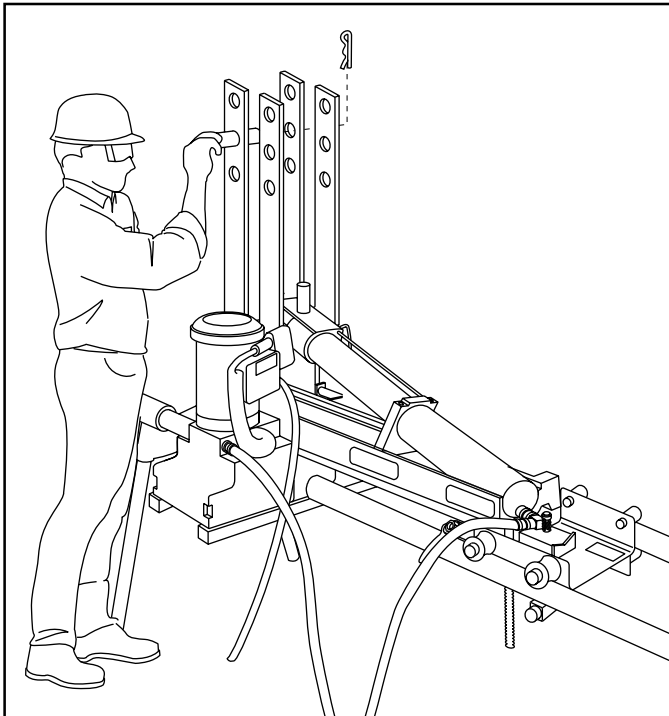

23. Insert one cylinder block pin (F) into the hole marked 3" CONDUIT as shown.

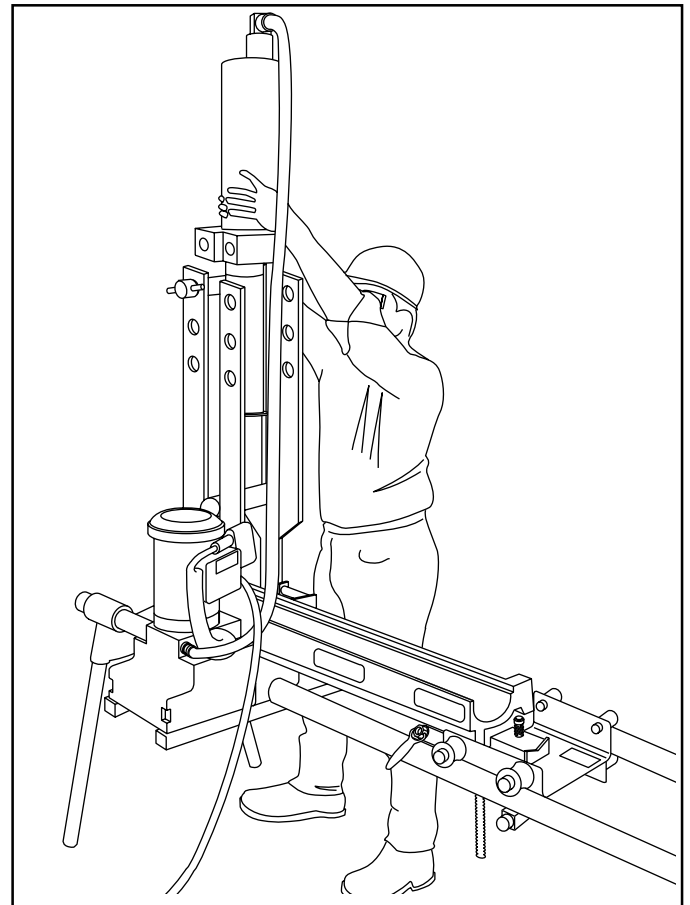

24 and 25. Swing the ram unit into position.

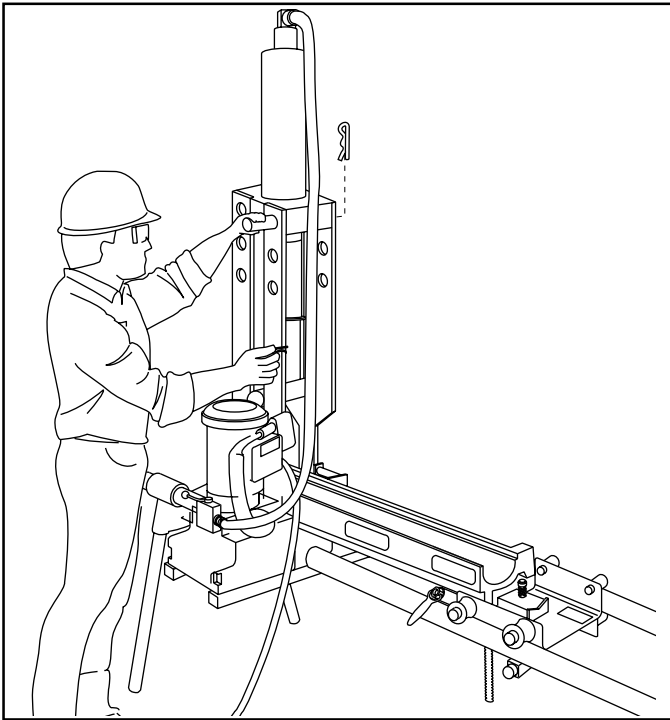
Assembly and Operation Instructions**881 and 881CT with 1813 Bending Table (cont'd)**

26. Remove the cylinder block pin from the 3 inch conduit hole in the connecting bar. Rotate the pump control lever clockwise to retract the ram. Position the cylinder block at the proper location for the size of conduit to be bent. Insert the two cylinder block pins (F) through the connecting bars and through the cylinder block. Secure the pins with two hitch pin clips (E).

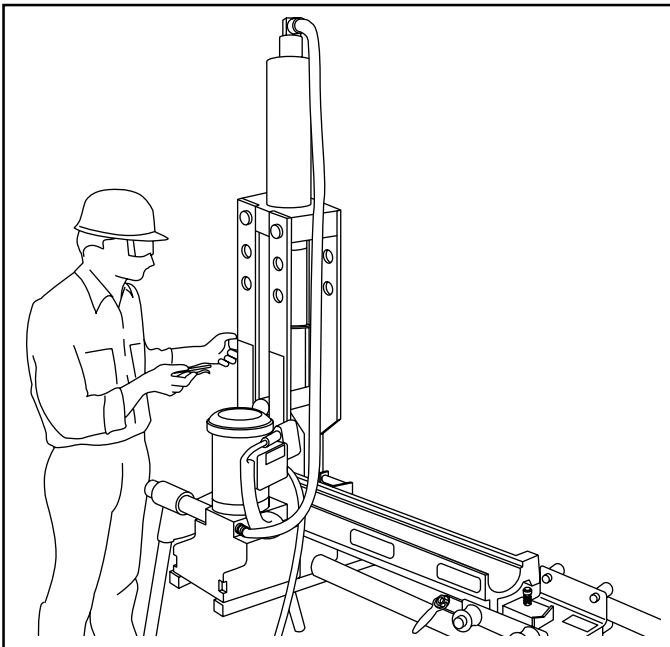

27. Remove the yoke pin from the ram positioner.

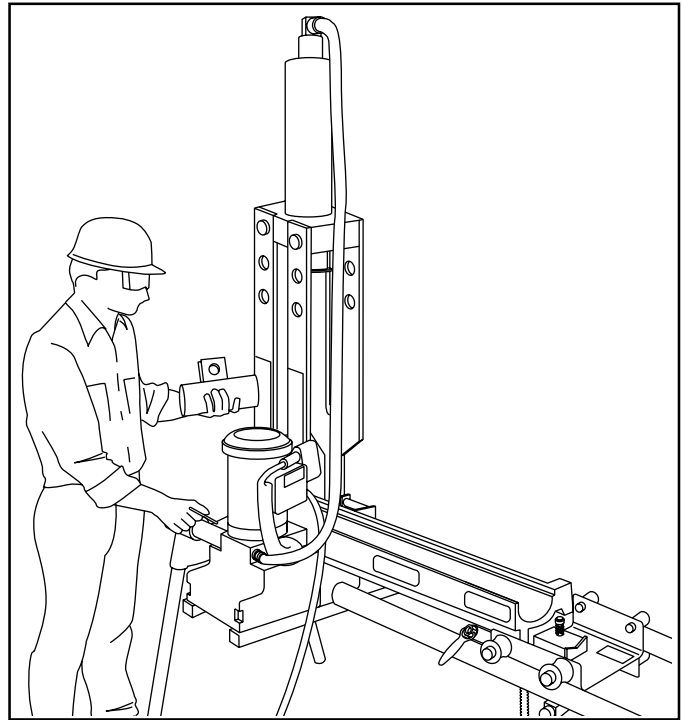

28. Remove the ram positioner from the connecting bar unit.

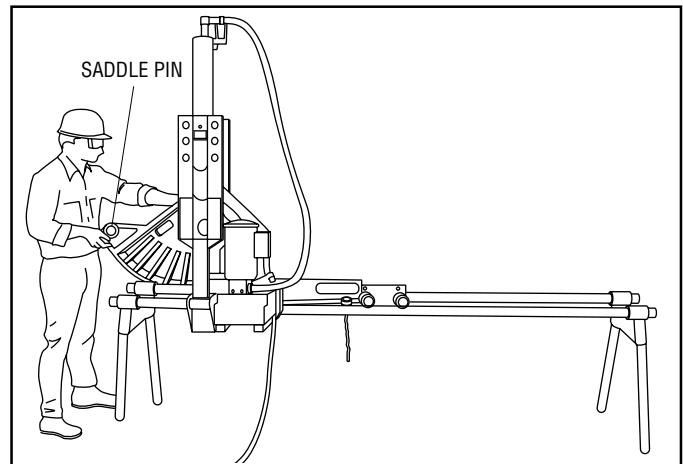

29. Load the shoe into the bender with the saddle pin hole to the left, as shown.

Assembly and Operation Instructions

881 and 881CT with 1813 Bending Table (cont'd)

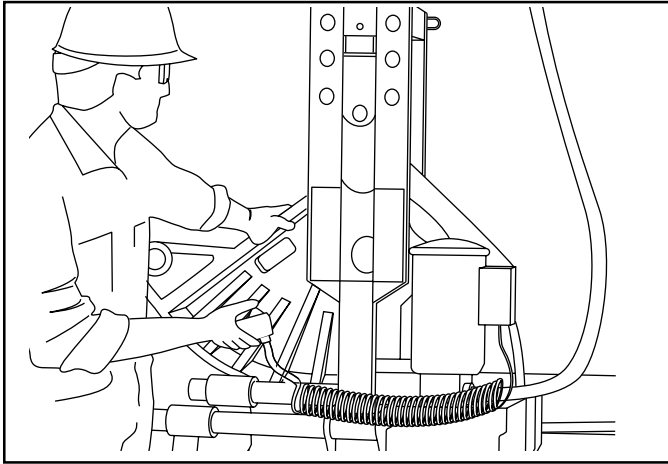

30. Rotate the pump control lever counterclockwise. Activate the hydraulic pump to advance the shoe until the yoke is aligned with the proper shoe yoke pin hole (EMT or IMC/Rigid).

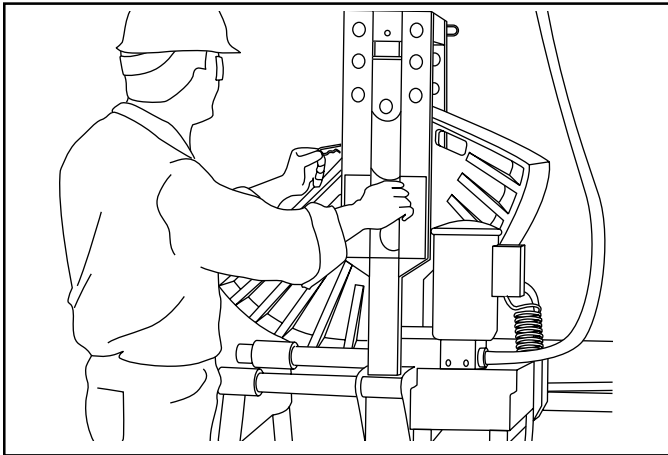

31. Attach the yoke to the shoe with the yoke pin (G). Secure the yoke pin with a hitch pin clip (E).

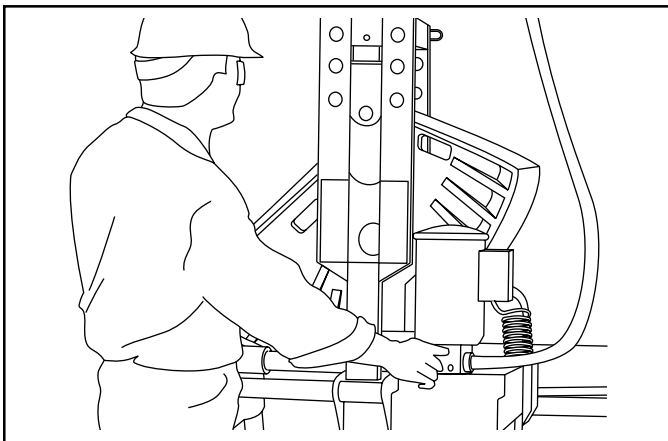

32. Rotate the pump control lever clockwise to retract the ram.

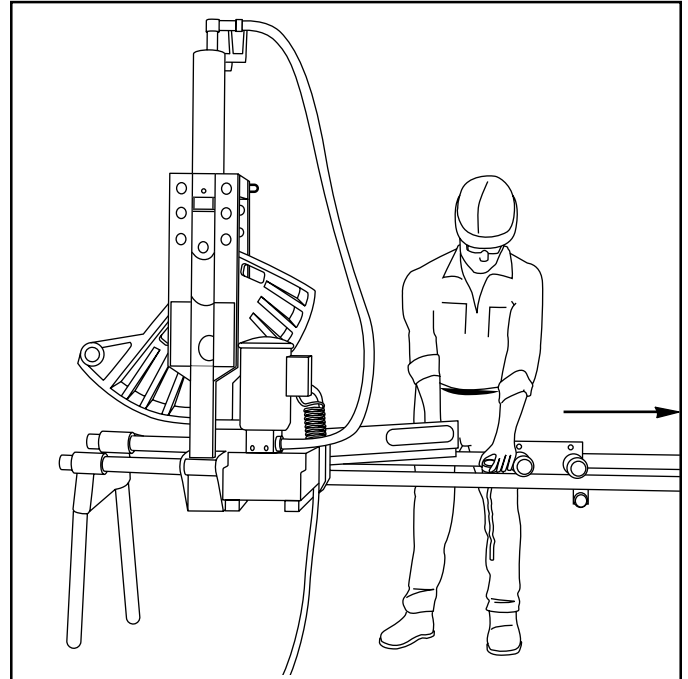

33. Remove the vise unit from its position below the follow bar. Slide the vise unit to the far end of the bending table.

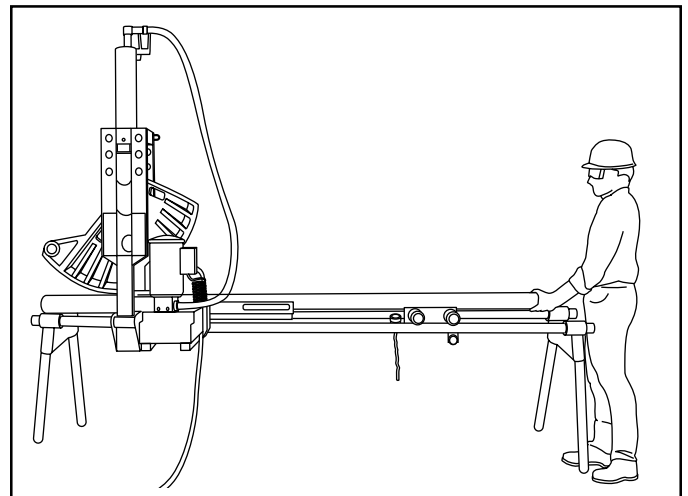

34. Insert the conduit to be bent. Rotate the pump control lever counterclockwise and advance the shoe until it nearly contacts the conduit.

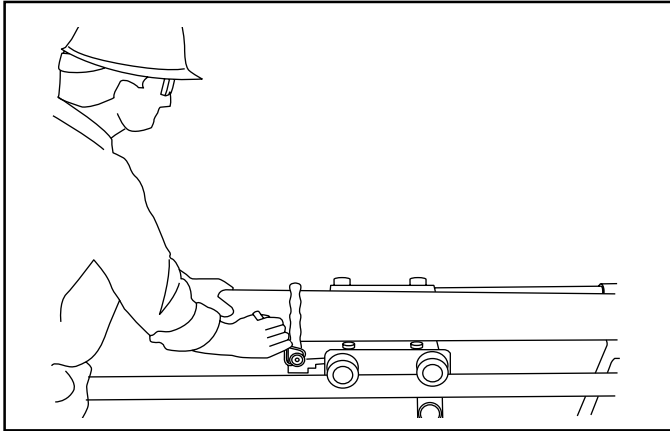
Assembly and Operation Instructions
881 and 881CT with 1813 Bending Table (cont'd)

35. Position the vise unit at a distance from the pump support so that the vise unit will not contact the pump support before the bend is complete. Clamp the conduit down in the vise unit.

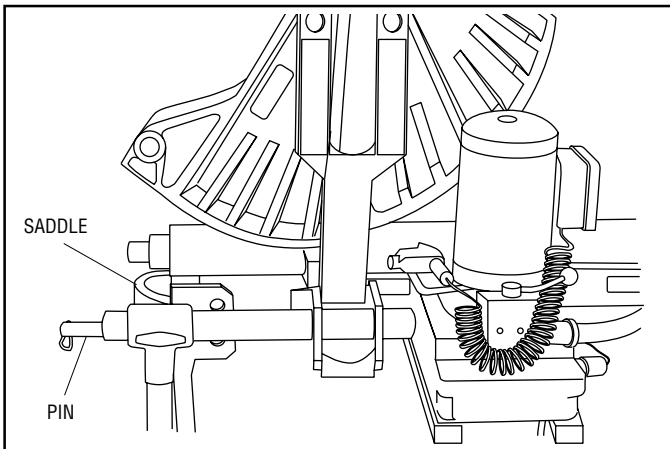

36. Push the follow bar back (to the right in the illustration) until the follow bar foot contacts the bender mounting unit. Position the saddle and saddle pin (M) where they can be reached for assembly.

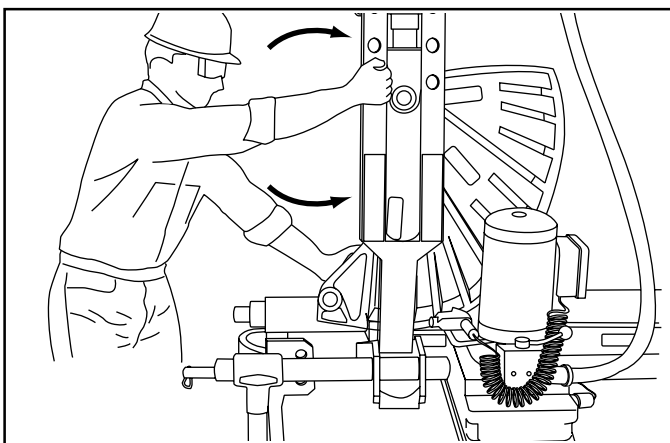

37. Rock the bender frame as shown and rotate the shoe back for the assembly of the saddle and pin.

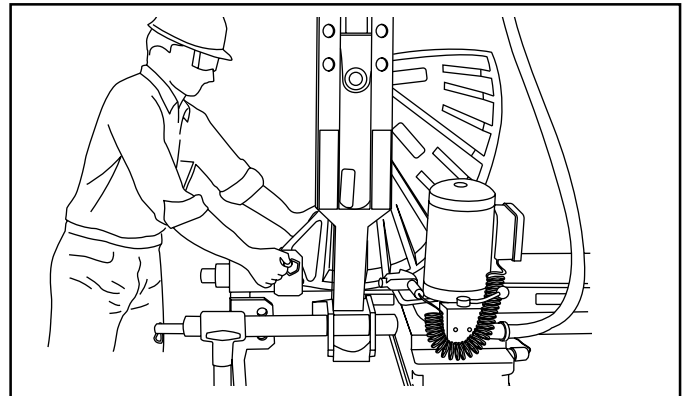

38. Hold the shoe against the conduit and position the saddle so the saddle insert is toward the operator. Align the hole in the saddle with the hole in the shoe and insert the saddle pin (M). Secure the saddle pin with the hitch pin clip (E).

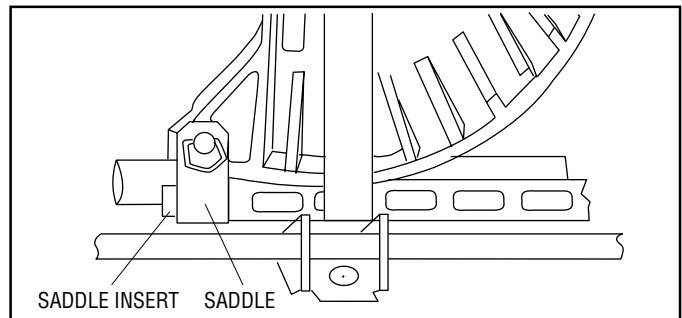

39. Allow the bender to rock forward and ensure that the follow bar comes forward with it, so that the follow bar contacts the saddle.

IMPORTANT

Follow the instructions and safety information supplied with your hydraulic pump.

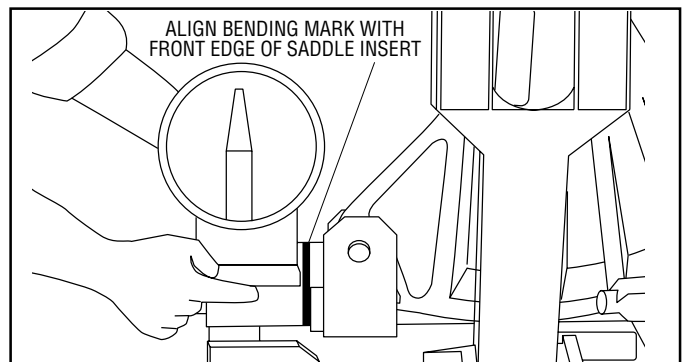

40. Rotate the pump control lever counterclockwise. Activate the hydraulic pump until the shoe just contacts the conduit. Check that the saddle and follow bar are snug, and that the follow bar is against the saddle, as shown. Be sure that the bending mark on the conduit is aligned with the front edge of the saddle insert. Attach the model 1805 Bending Degree Indicator (35) to the conduit. Zero the indicator by rotating the degree wheel.

Assembly and Operation Instructions

881 and 881CT with 1813 Bending Table (cont'd)

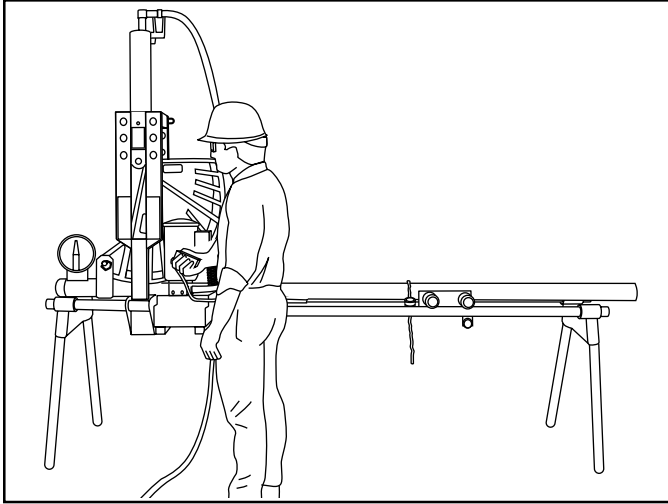

41. Activate the hydraulic pump to begin the bend.

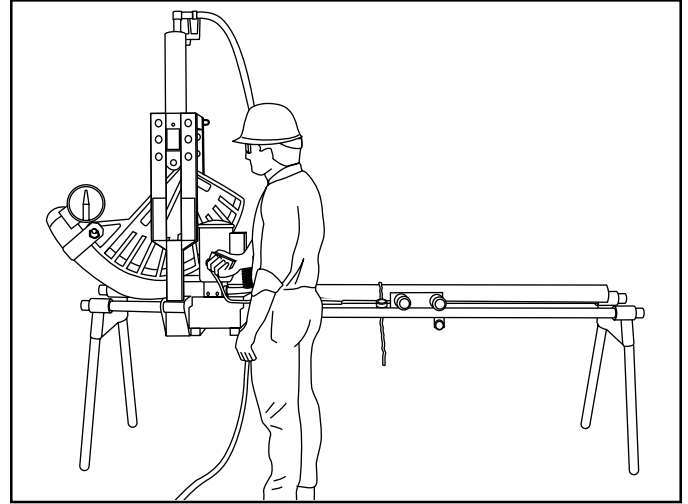

44. 45° of bend.

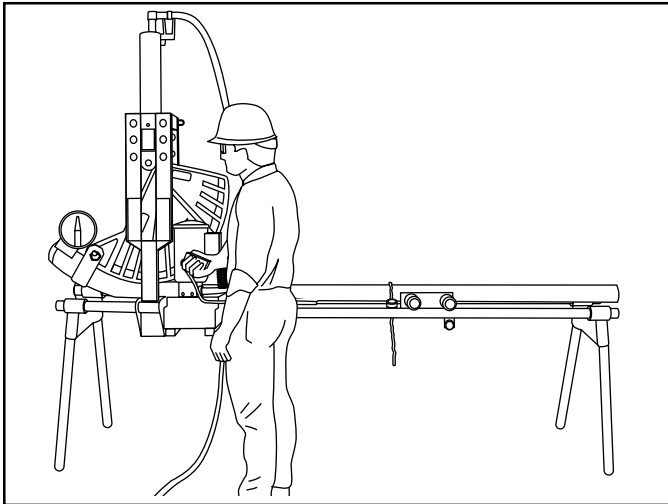

42. 15° of bend.

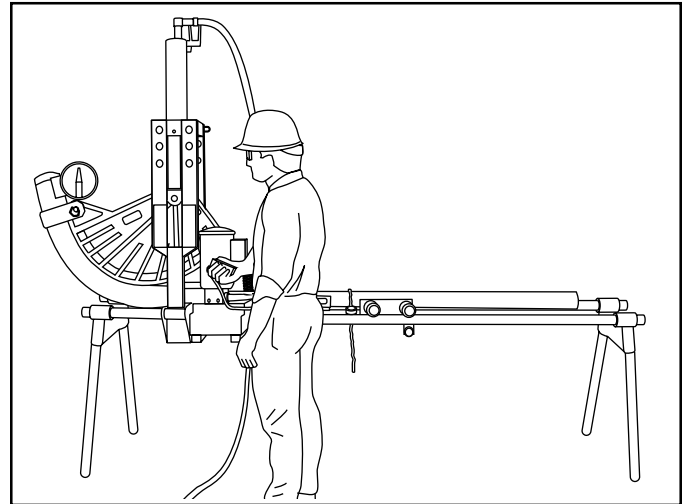

45. 60° of bend.

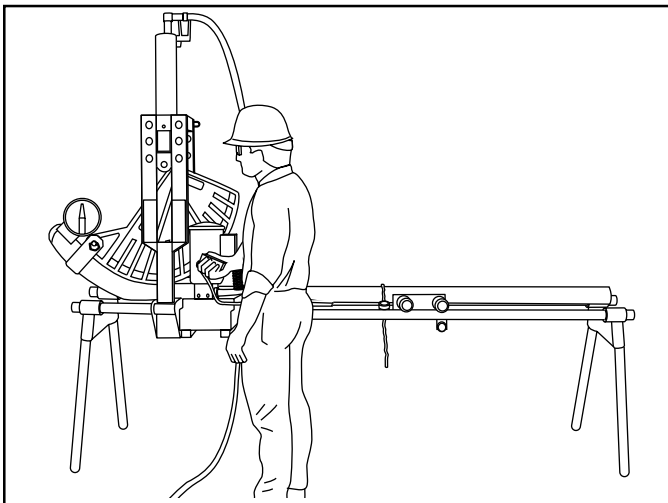

43. 30° of bend.

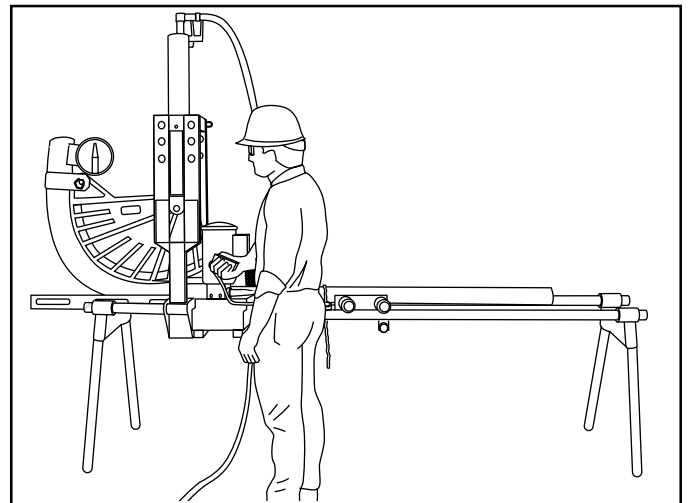

46. 75° of bend.

Assembly and Operation Instructions

881 and 881CT with 1813 Bending Table (cont'd)

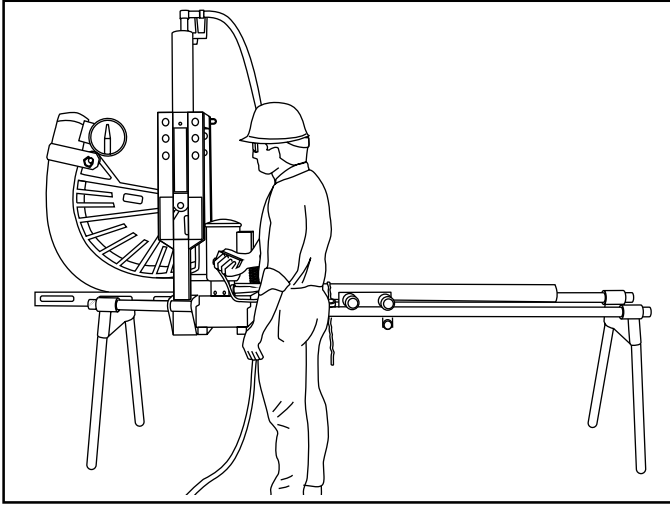

47. 90° of bend.

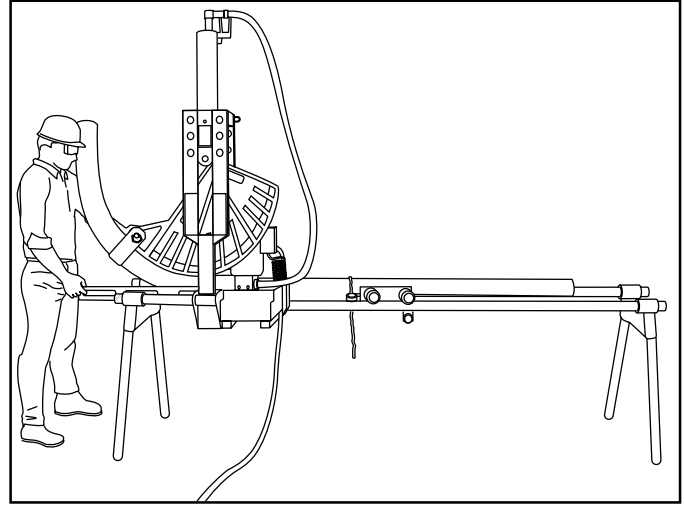

50. Push the follow bar back to the start position.

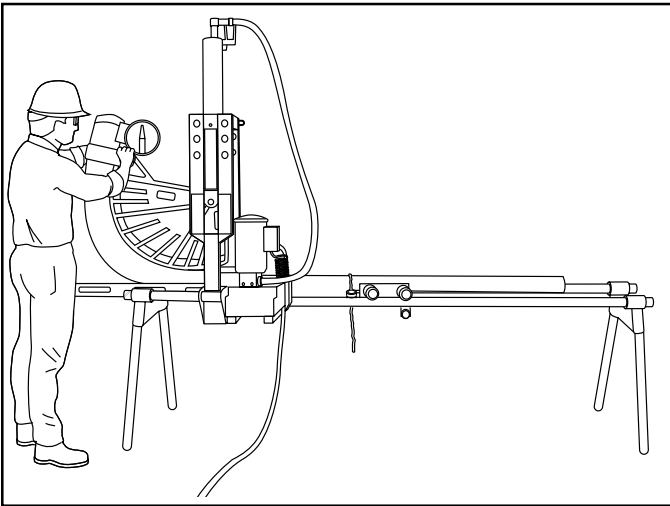

48. Remove the 1805 Bending Degree Indicator.

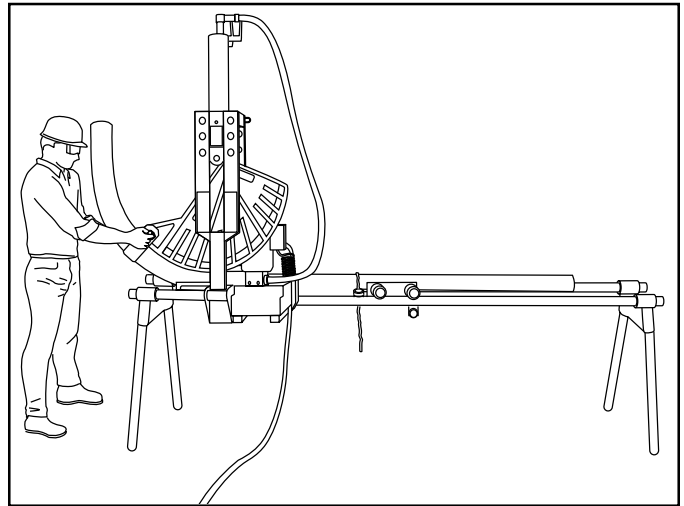

51. Remove the saddle pin and saddle.

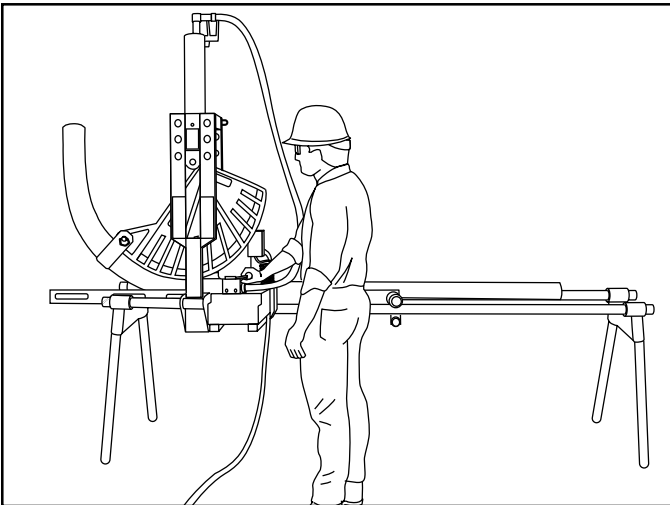

49. Rotate the pump control lever clockwise to retract the shoe.

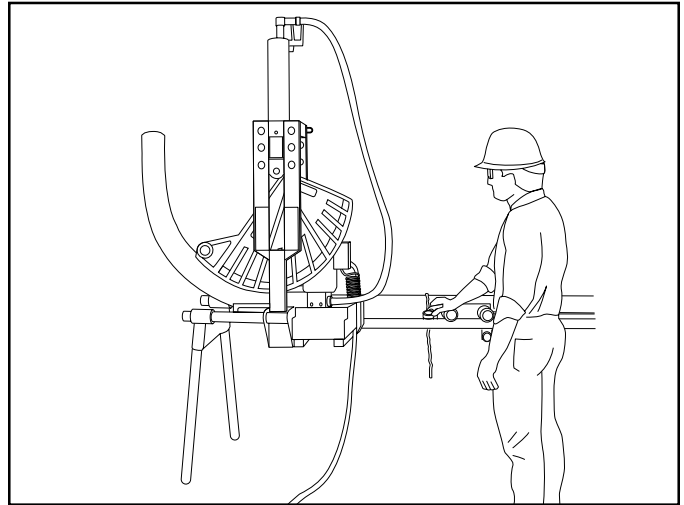

52. Release the vise chain.

Assembly and Operation Instructions

881 and 881CT with 1813 Bending Table (cont'd)

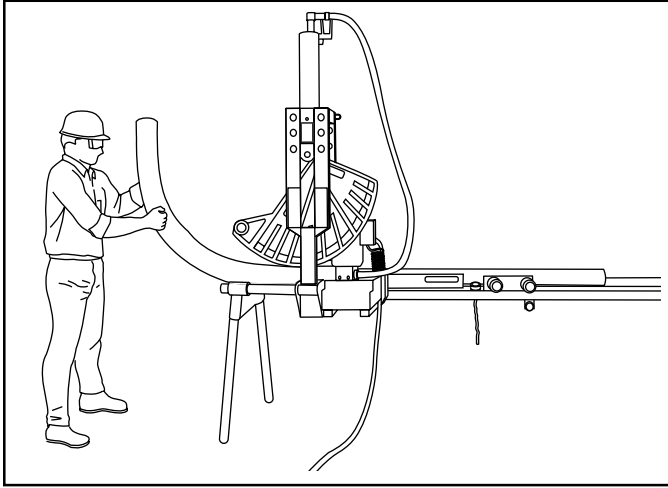

53. Remove the conduit from the bender.

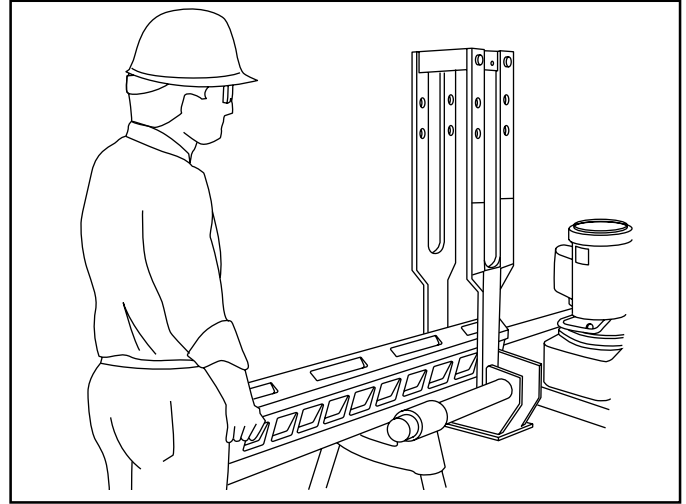

58. To change the follow bar, twist and remove.

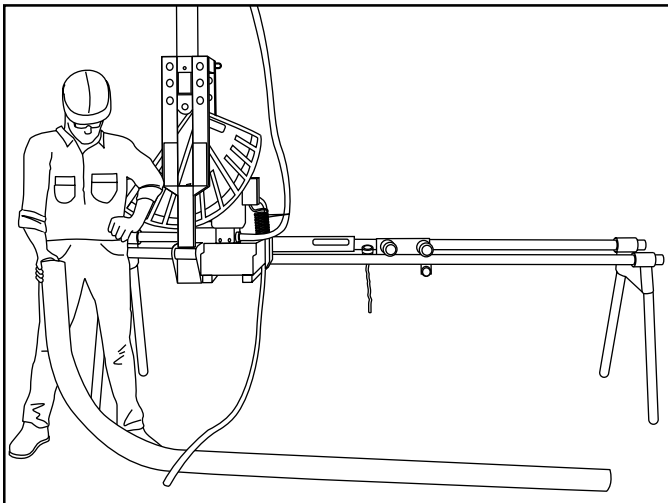
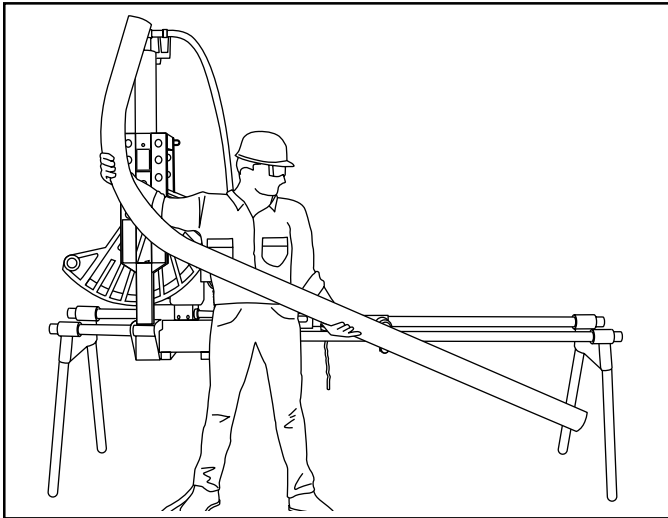

54 and 55. The 90° bend is complete.

Glossary of Bending Terms with Illustrations

1. **amount of offset**—the distance that the conduit or pipe must be re-routed to avoid an obstruction; see offset in this glossary and Offsets in Laying Out Bends in this manual

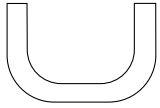

2. **back-to-back bend**—any U-shaped bend formed by two parallel 90-degree bends with a straight section of conduit or pipe between the bends

3. **center-to-center distance**—the distance between the successive bends that make up an offset or a three-bend saddle

4. **depth of offset**—same as amount of offset

5. **height of offset**—same as amount of offset

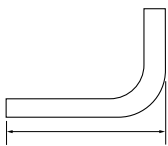

6. **leg length**—the distance from the end of a horizontal section of conduit or pipe to the bend; measured from the end to the center line, inside edge, or outside edge of the conduit or pipe.

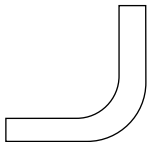

7. **90° bend**—any bend that changes the direction of the conduit or pipe by 90 degrees

8. **O. D.**—the size of any piece of conduit or pipe as measured by its outside diameter

9. **offset bend**—two bends with the same degree of bend; used to avoid an obstruction blocking the run of the conduit or pipe

10. **ram travel**—the distance that the ram of a hydraulic bender moves to accomplish a particular bend; inches of ram travel are proportionate to degrees of bend

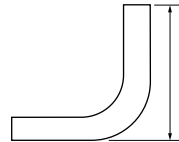

11. **rise**—the distance from the end of a vertical section of conduit or pipe to the bend; measured from the end to the center line, inside edge, or outside edge of the conduit or pipe

12. **shot**—a single bend

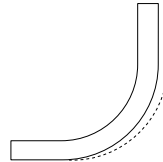

13. **springback**—the amount, measured in degrees, that a conduit or pipe tends to straighten after being bent

14. **stub**—same as rise

15. **stub-up**—same as rise

Laying Out One-Shot 90° Bends

1. Measure the length of the required stub.
2. Find the Minimum Stub Length on the Table 2: Deduct, Stub Dimensions, and Minimum Distance from End of Conduit. The stub you require must be equal to or longer than the minimum stub length.
3. Measure and mark the stub length on the conduit. This is Mark 1.
4. Find the Deduct on Table 2. Subtract the Deduct from Mark 1 and make a new mark. This is Mark 2, or the bending mark. Find the Minimum Distance from End of Conduit in Table 2; be sure that Mark 2 is at least this distance from the end of the conduit.
5. Align Mark 2 with the outside edge of the saddle. Bend the conduit—see the instructions under Assembly and Operating Instructions.

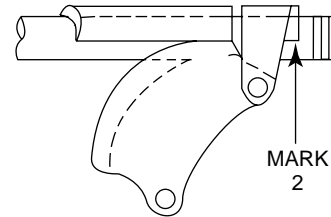
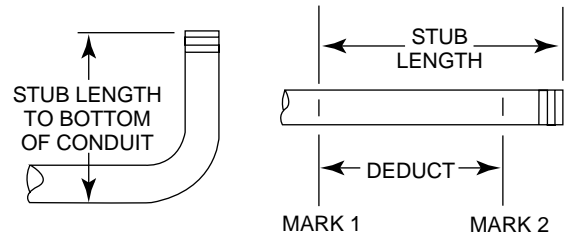

Table 2

Deduct, Stub Dimensions, Minimum Distance from End of Conduit

CONDUIT SIZE →	2-1/2	3	3-1/2	4
EMT				
Deduct	21-1/2	24	27-3/4	32-1/4
Minimum Stub Length	24	27	31-1/4	36-1/4
Minimum Distance from End of Conduit	2-1/2	3	3-1/2	4
IMC-RIGID				
Deduct	21-1/2	24-1/4	28-1/4	32-1/2
Minimum Stub Length	24	26-3/4	30-3/4	35
Minimum Distance from End of Conduit	2-1/2	2-1/2	2-1/2	2-1/2

Table 3
Ram Travel

(Figures are approximate)

Ram Travel: Read Scale at Edge of Block

Note: Ram Scale Must be Set on Zero

*Note: **Calibrate Bender Before Bending** Snug up bender by advancing ram until shoe, conduit and follow bar are snug. (Do not squeeze or begin to bend.) Stop pump. Compare reading on scale with appropriate Snug-Up 0° column on ram travel charts. Note variance if any. Incorporate this variance in ram travel measurements used for bending the same size and type of conduit.*

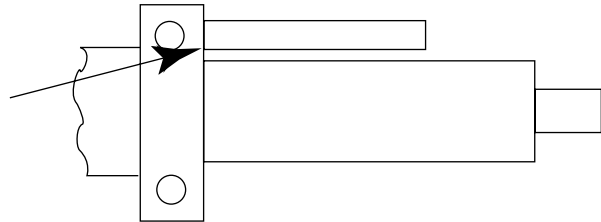

DEGREE OF BEND	EMT					
	2-1/2 (90°)	3 (90°)	3-1/2 (90°)	4 (90°)	3-1/2 (45°)	4 (45°)
SNUG-UP						
0°	4-3/16	3-7/8	3-1/8	2-3/8	5	3-9/16
10°	5	4-15/16	4-1/8	3-1/4	6-5/8	5-1/8
15°	5-1/4	5-5/16	4-1/2	3-3/4	7-1/8	5-1/2
30°	6-3/16	6-5/16	5-1/2	4-13/16	8-13/16	6-3/8
45°	7-1/8	7-5/16	6-1/2	6	10-1/4	7-3/4
60°	8	8-3/8	7-1/2	7-1/4	See Table 4	See Table 4
90°	9-1/2	10-3/8	9-13/16	9-5/8	See Table 4	See Table 4

DEGREE OF BEND	IMC					
	2-1/2 (90°)	3 (90°)	3-1/2 (90°)	4 (90°)	3-1/2 (45°)	4 (45°)
SNUG-UP						
0°	2-7/8	2-1/4	2-1/16	1-7/16	5	2-3/8
10°	4	3-5/8	3-1/8	2-5/8	6-5/8	4-5/16
15°	4-7/16	4-1/16	3-9/16	3-1/4	7-1/8	4-15/16
30°	5-3/4	5-3/8	5-1/16	4-5/8	8-13/16	6-5/8
45°	7-3/16	6-15/16	6-7/16	6-1/4	10-1/4	8-1/2
60°	8-11/16	8-7/16	7-7/8	7-7/8	See Table 4	See Table 4
90°	11	11-5/8	10-7/8	11-1/8	See Table 4	See Table 4

DEGREE OF BEND	RIGID					
	2-1/2 (90°)	3 (90°)	3-1/2 (90°)	4 (90°)	3-1/2 (45°)	4 (45°)
SNUG-UP						
0°	2-7/8	2-1/4	2	1-5/16	4-5/8	2-1/8
10°	3-15/16	3-5/8	3	2-3/8	6-3/8	4-1/16
15°	4-3/8	4-1/16	3-1/2	3	6-13/16	4-3/4
30°	5-3/4	5-3/8	4-7/8	4-1/2	8-1/2	6-1/2
45°	7-1/8	6-15/16	6-1/4	6-1/8	10-1/8	8-1/4
60°	8-1/2	8-7/16	7-3/4	7-3/4	See Table 4	See Table 4
90°	11	11-5/8	10-3/4	11	See Table 4	See Table 4

Laying Out Two-Shot 90° Bends for 3-1/2" and 4" Conduit (881 Only)

1. Measure the length of the required stub.
2. Find the Minimum Stub Length on the Table 2: Deduct, Stub Dimensions, and Minimum Distance from End of Conduit. The stub you require must be equal to or longer than the minimum stub length.
3. Measure and mark the stub length on the conduit. This is Mark 1
4. Find the Deduct on Table 2. Subtract the Deduct from Mark 1 and make a new mark. This is Mark 2, or the first bending mark. Find the Minimum Distance from End of Conduit in Table 2; be sure that Mark 2 is at least this distance from the end of the conduit.
5. Measure and make Mark 3, or the second bending mark:
 - For 3-1/2" conduit, Mark 3 must be 14-1/2 inches from Mark 2.
 - For 4-1/2" conduit, Mark 3 must be 15-1/2 inches from Mark 2.
6. See Figure 6: For Making 90° Bends on 3-1/2" and 4" Conduit. Using the suggested amount of ram travel, align Mark 2 with the outside edge of the saddle and bend the conduit.
7. Align mark 3 with the outside of the saddle.

Note: A portion of the previous bend will fall inside the shoe.
8. Bend the conduit until the 90° bend is complete.

EMT	CONDUIT SIZE	1ST BEND	90°
RAM	3-1/2	10-3/16	9-3/4
	4	8-3/16	8-3/16

IMC	CONDUIT SIZE	1ST BEND	90°
RAM	3-1/2	11-1/4	10-11/16
	4	9	9-1/16

RIGID	CONDUIT SIZE	1ST BEND	90°
RAM	3-1/2	11-1/8	10-1/2
	4	8-5/16	8-7/8

FIRST BEND

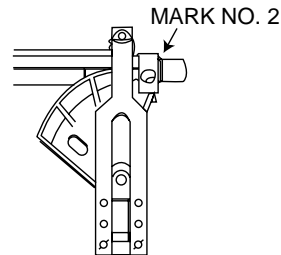

SECOND BEND

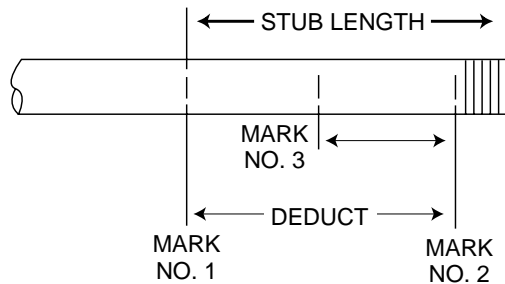
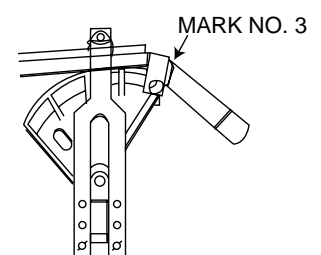

IMPORTANT

The 45° two-shot shoes and follow bars are not interchangeable with the 90° one-shot shoes and follow bars. See Illustration.

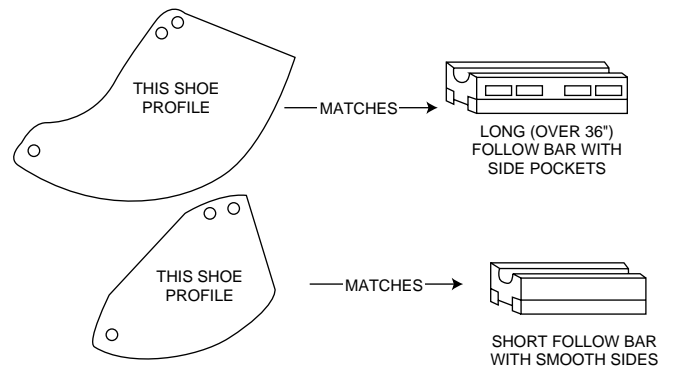

Laying Out Bends

The following drawings and bending charts are intended to provide the information necessary to accomplish the most common types of bends. The Special Bending Information Chart contains precise measurements for the most commonly needed bends.

Stubs

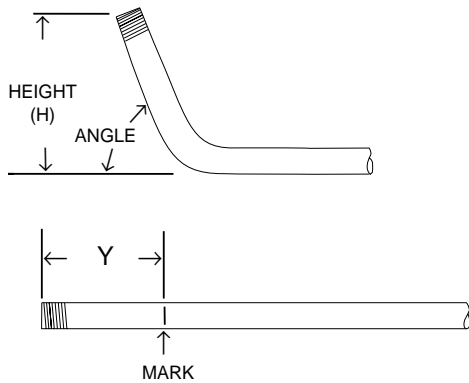

1. Select the size and type of conduit. Determine the height of stub and the angle of bend.
2. Find the chart that corresponds to the size and type of conduit selected in Step 1.
3. Under the column labeled ANGLE, find the angle of bend.
4. Find the row labeled Y. In the row at the top of the page, find the height (H) of the stub.
5. The number shown at the intersection of row Y and the appropriate H column is the distance Y. Place the bending mark Y inches from the end of the conduit.
6. Bend the conduit.

Offsets

An offset is used to route the conduit around an obstruction. To make an offset, two equal bends are required. The distance between the two bends is the center-to-center distance. This is represented by L1 in the bending tables.

When working past an obstruction, it is necessary to determine the location of the first bend. The center-to-center distance is then used to find the location of the second bend. See Offsets: Working Past an Obstruction. When working toward an obstruction, it is necessary to determine the location of the second bend. The center-to-center distance is then used to find the location of the first bend. See Offsets: Working Toward an Obstruction.

Offsets: Working Past an Obstruction

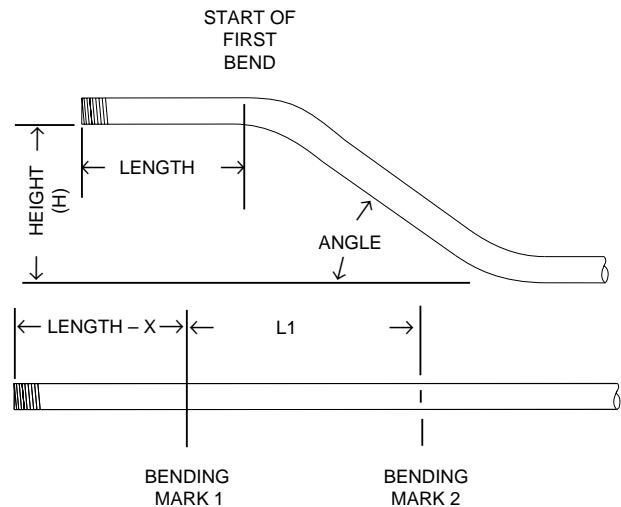

1. Select the size and type of conduit. Measure the height of the obstruction and the distance labeled LENGTH. Select the angle to be used.
2. Find the chart that corresponds to the size and type of conduit selected in Step 1.
3. To the right of the size and type of conduit, find the dimension labeled X. Subtract X from LENGTH. Place the first bending mark this distance from the end of the conduit.
4. Under the column labeled ANGLE, find the angle of bend. Find the row labeled L1. In the row at the top of the page, find the height (H) of the offset.
5. The number shown at the intersection of row L1 and the appropriate H column is L1. Place the second bending mark L1 inches from the first bending mark.
6. Bend the conduit.

Laying Out Bends (cont'd)

Offsets: Working Toward an Obstruction

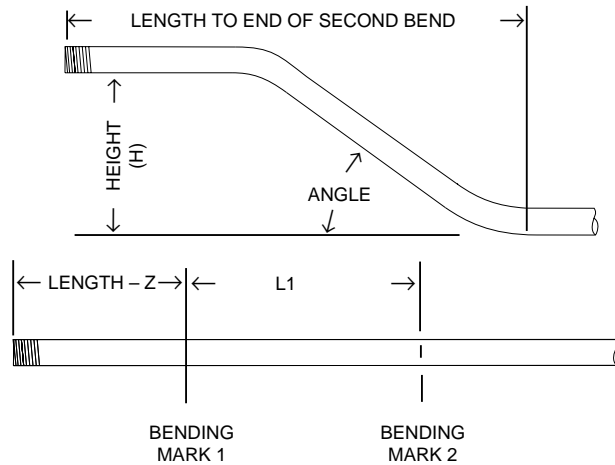

1. Select the size and type of conduit. Measure the height of the obstruction and the distance labeled **LENGTH TO END OF SECOND BEND**. Select the angle to be used.
2. Find the chart that corresponds to the size and type of conduit selected in Step 1.
3. Under the column labeled **ANGLE**, find the angle of bend. Find the row labeled **Z**. In the row at the top of the page, find the height (**H**) of the offset.
4. The number shown at the intersection of the **Z** row and the appropriate **H** column is **Z**. Subtract **Z** from **LENGTH TO THE END OF SECOND BEND**. Place the first bending mark this distance from the end of the conduit.
5. In the same column, find the row labeled **L1**. Place the second bending mark **L1** inches from the first bending mark.
6. Bend the conduit.

Three-Bend Saddle

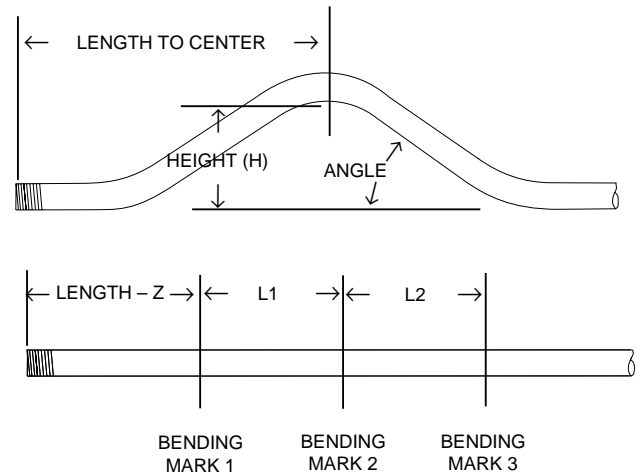

1. Select the size and type of conduit. Measure the height of the obstruction and the distance from the end of the conduit to the center (**LENGTH TO CENTER**) of the bend. Select the angle to be used.
Note: The second bend angle will be twice the number of degrees as the first and third bends.
2. Find the chart that corresponds to the size and type of conduit selected in Step 1.
3. Under the column labeled **ANGLE**, find the angle of bend needed. Find the row labeled **Z**. In the row at the top of the page, find the height (**H**) of the offset.
4. The number shown at the intersection of the **Z** row and the appropriate **H** column is **Z**. Subtract **Z** from the **LENGTH TO CENTER**. Place the first bending mark this distance from the end of the conduit.
5. In the same column, find the row labeled **L1**. Place the second bending mark **L1** inches from the first bending mark.
6. In the same column, find the row labeled **L2**. Place the third bending mark **L2** inches from the second bending mark.
7. Bend the conduit.

Laying Out Bends (cont'd)

Four-Bend Saddle

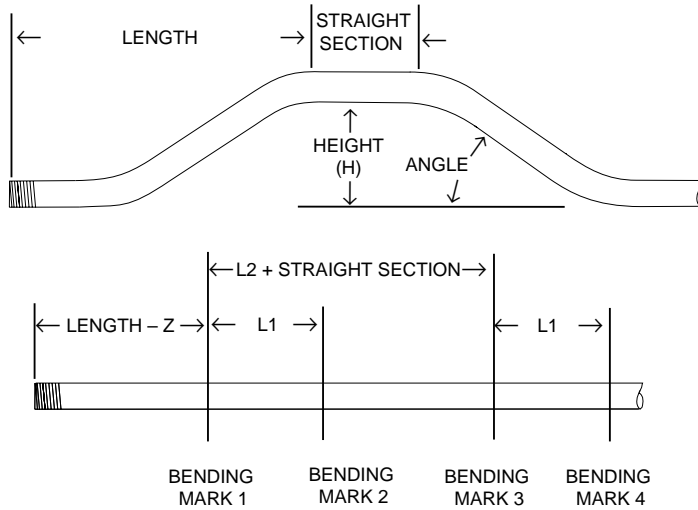

1. Select the size and type of conduit. Measure the height of the obstruction, the distance labeled LENGTH, and the distance labeled STRAIGHT SECTION. Select the angle to be used.
2. Find the chart that corresponds to the size and type of conduit selected in Step 1.
3. Under the column labeled ANGLE, find the angle of bend needed. Find the row labeled Z. In the row at the top of the page, find the height (H) of the offset.
4. The number shown is Z. Subtract Z from the LENGTH. Place the first bending mark this distance from the end of the conduit.
5. In the same column, find the row labeled L1. Place the second bending mark L1 inches from the first bending mark.
6. In the same column, find the row labeled L2. Add L2 to the STRAIGHT SECTION. Place the third bending mark this distance from the **first** bending mark.
7. Make the final bending mark L1 inches from the third bending mark.
8. Bend the conduit.

U-Bends

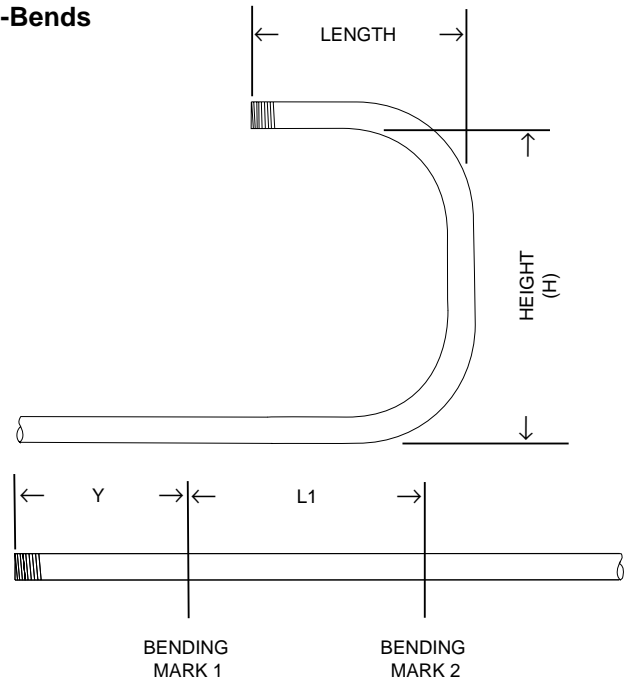

1. Select the size and type of conduit. Determine the LENGTH and the HEIGHT.
2. Find the chart that corresponds to the size and type of conduit selected in Step 1.
3. Under the column labeled ANGLE, find 90°.
4. Find the row labeled Y. In the row at the top of the page, find the height (H) that corresponds to the LENGTH.
5. The number shown at the intersection of the Y row and the appropriate H column is the distance Y. Place the bending mark Y inches from the end of the conduit.
6. Find the row labeled L1, and go to the right to find the height (H) that corresponds to the HEIGHT.
7. The number shown at the intersection of the L1 row and the appropriate H column is L1. Place the second bending mark L1 inches from the first mark.
8. Bend the conduit.



Special Bending Information Chart

DIM	ANGLE	HEIGHT - H										
		10"	12"	15"	18"	24"	30"	36"	42"	48"	60"	
2-1/2 EMT		Dia. = 2.875		Radius = 13.9			x = 6.15					
Y	15.00	25.10	32.83	44.42	56.01	79.19	102.38	125.56	148.74	171.92	218.29	
L1	15.00	38.62	46.34	57.93	69.53	92.71	115.89	139.07	162.25	185.44	231.80	
L2	15.00	42.26	49.98	61.57	73.16	96.35	119.53	142.71	165.89	189.08	235.44	
Z	15.00	47.13	54.59	65.79	76.99	99.38	121.77	144.16	166.56	188.95	233.73	
MINIMUM H = 2.54												
Y	22.50	13.46	18.69	26.53	34.37	50.04	65.72	81.40	97.08	112.76	144.12	
L1	22.50	26.06	31.29	39.13	46.97	62.64	78.32	94.00	109.68	125.36	156.72	
L2	22.50	31.52	36.74	44.58	52.42	68.10	83.78	99.46	115.14	130.82	162.17	
Z	22.50	35.82	40.65	47.89	55.14	69.62	84.11	98.59	113.08	127.56	156.53	
MINIMUM H = 4.47												
Y	30.00	7.25	11.25	17.25	23.25	35.25	47.25	59.25	71.25	83.25	107.25	
L1	30.00	19.83	23.83	29.83	35.83	47.83	59.83	71.83	83.83	95.83	119.83	
L2	30.00	27.11	31.11	37.11	43.11	55.11	67.11	79.11	91.11	103.11	127.11	
Z	30.00	30.92	34.38	39.58	44.78	55.17	65.56	75.95	86.35	96.74	117.52	
MINIMUM H = 6.80												
Y	45.00		3.03	7.27	11.52	20.00	28.49	36.97	45.46	53.94	70.91	
L1	45.00		16.37	20.62	24.86	33.34	41.83	50.31	58.80	67.28	84.25	
L2	45.00		27.29	31.53	35.77	44.26	52.75	61.23	69.72	78.20	95.17	
Z	45.00		29.67	32.67	35.67	41.67	47.67	53.67	56.67	65.67	77.67	
MINIMUM H = 12.49												
Y	60.00			1.49	4.95	11.88	18.81	25.73	32.66	39.59	53.45	
L1	60.00					26.22	33.15	40.07	47.00	53.93	67.79	
L2	60.00					40.77	47.70	54.63	61.56	68.49	82.34	
Z	60.00					36.06	39.52	42.98	46.45	49.91	56.84	
MINIMUM H = 19.23												
Y	90.00					2.51	8.51	14.51	20.51	26.51	38.51	
L1	90.00							30.03	36.03	42.03	54.03	
L2	90.00							51.87	57.87	63.87	75.87	
Z	90.00							33.95	33.95	33.95	33.95	
MINIMUM H = 33.95												
3 EMT		Dia. = 3.5		Radius = 16.48			x = 5.77					
Y	15.00	23.94	31.66	43.25	54.85	78.03	101.21	124.39	147.57	170.76	217.12	
L1	15.00	38.61	46.34	57.93	69.52	92.70	115.89	139.07	162.25	185.43	231.80	
L2	15.00	42.93	50.65	62.25	73.84	97.02	120.20	143.38	166.57	189.75	236.11	
Z	15.00	47.43	54.89	66.09	77.29	99.68	122.07	144.46	166.86	189.25	234.03	
MINIMUM H = 2.62												
Y	22.50	12.51	17.74	25.58	33.42	49.09	64.77	80.45	96.13	111.81	143.17	
L1	22.50	26.05	31.27	39.11	46.95	62.63	78.31	93.99	109.67	125.35	156.70	
L2	22.50	32.52	37.74	45.58	53.42	69.10	84.78	100.46	116.14	131.82	163.17	
Z	22.50	36.47	41.30	48.54	55.78	70.27	84.75	99.24	113.72	128.21	157.18	
MINIMUM H = 4.72												
Y	30.00	6.31	10.31	16.31	22.31	34.31	46.31	58.31	70.31	82.31	106.31	
L1	30.00	19.80	23.80	29.80	35.80	47.80	59.80	71.80	83.80	95.80	119.80	
L2	30.00	28.43	32.43	38.43	44.43	56.43	68.43	80.43	92.43	104.43	128.43	
Z	30.00	31.92	35.39	40.58	45.78	56.17	66.56	76.96	87.35	97.74	118.52	
MINIMUM H = 7.30												
Y	45.00		1.90	6.14	10.38	18.87	27.36	35.84	44.33	52.81	69.78	
L1	45.00			20.50	24.75	33.23	41.72	50.20	58.69	67.17	84.14	
L2	45.00			33.45	37.69	46.18	54.66	63.15	71.63	80.12	97.09	
Z	45.00			34.42	37.42	43.42	49.42	55.42	61.42	67.42	79.42	
MINIMUM H = 13.73												
Y	60.00			0.02	3.48	10.41	17.34	24.26	31.19	38.12	51.98	
L1	60.00					25.94	32.87	39.80	46.73	53.65	67.51	
L2	60.00					43.20	50.13	57.06	63.98	70.91	84.77	
Z	60.00					38.66	42.12	45.58	49.05	52.51	59.44	
MINIMUM H = 21.48												
Y	90.00					0.00	6.00	12.00	18.00	24.00	36.00	
L1	90.00								34.93	40.93	52.93	
L2	90.00								60.81	66.81	78.81	
Z	90.00								38.73	38.73	38.73	
MINIMUM H = 38.73												



881 and 881CT Cam Track® Hydraulic Benders

Special Bending Information Chart (cont'd)

		HEIGHT - H										
DIM	ANGLE	10"	12"	15"	18"	24"	30"	36"	42"	48"	60"	
3-1/2 EMT		Dia. = 4		Radius = 19.18			x = 6.56					
Y	15.00	21.82	29.55	41.14	52.73	75.92	99.10	122.28	145.46	168.65	215.01	
L1	15.00	38.61	46.34	57.93	69.52	92.70	115.88	139.06	165.25	185.43	231.79	
L2	15.00	43.63	51.36	62.95	74.54	97.72	120.90	144.09	167.27	190.45	236.81	
Z	15.00	48.93	56.39	67.59	78.79	101.18	123.57	145.96	168.36	190.75	235.53	
MINIMUM H = 3.00												
Y	22.50	10.53	15.76	23.60	31.43	47.11	62.79	78.47	94.15	109.83	141.19	
L1	22.50	26.03	31.26	39.10	46.94	62.62	78.30	93.97	109.65	125.33	156.69	
L2	22.50	33.56	38.79	46.63	54.47	70.15	85.83	101.51	117.18	132.86	164.22	
Z	22.50	38.33	43.16	50.40	57.65	72.13	86.62	101.10	115.59	130.37	159.04	
MINIMUM H = 5.43												
Y	30.00	4.30	8.30	14.30	20.30	32.30	44.30	56.30	68.30	80.30	104.30	
L1	30.00	19.76	23.76	29.76	35.76	47.76	59.76	71.76	83.76	95.76	119.76	
L2	30.00	29.81	33.81	39.81	45.81	57.81	69.81	81.81	93.81	105.81	129.81	
Z	30.00	34.16	37.62	42.82	48.02	58.41	68.80	79.19	89.58	99.98	120.76	
MINIMUM H = 8.42												
Y	45.00			3.88	8.12	16.61	25.09	33.58	42.06	50.55	67.52	
L1	45.00				24.63	33.12	41.60	50.09	58.57	67.06	84.03	
L2	45.00				39.69	48.18	56.67	65.15	73.64	82.12	99.09	
Z	45.00				40.45	46.45	52.45	58.45	64.45	70.45	82.45	
MINIMUM H = 15.87												
Y	60.00				0.84	7.77	14.7	21.63	28.55	35.48	49.34	
L1	60.00						32.58	39.51	46.44	53.36	67.22	
L2	60.00						52.66	59.59	66.52	73.45	87.31	
Z	60.00						46.03	49.49	52.96	56.42	63.35	
MINIMUM H = 24.86												
Y	90.00						2.26	8.26	14.26	20.26	32.26	
L1	90.00									39.77	51.77	
L2	90.00									69.90	81.90	
Z	90.00									44.92	44.92	
MINIMUM H = 44.92												
4 EMT		Dia. = 4.5		Radius = 21.5			x = 8.5					
Y	15.00	18.61	26.34	37.93	49.52	72.71	95.89	119.07	142.25	165.43	211.80	
L1	15.00	38.60	46.33	57.92	69.51	92.70	115.88	139.06	162.24	185.43	231.79	
L2	15.00	44.23	51.96	63.55	75.14	98.33	121.51	144.69	167.87	191.05	237.42	
Z	15.00	51.48	58.95	70.14	81.34	103.73	126.12	148.51	170.91	193.30	238.08	
MINIMUM H = 3.67												
Y	22.50	7.48	12.70	20.54	28.38	44.06	59.74	75.42	91.10	106.77	138.13	
L1	22.50	26.02	31.25	39.09	46.93	62.60	78.28	93.96	109.64	125.32	156.68	
L2	22.50	34.46	39.69	47.53	55.37	71.05	86.73	102.41	118.08	133.76	165.12	
Z	22.50	41.20	46.02	53.27	60.51	74.99	89.48	103.96	118.45	132.94	161.91	
MINIMUM H = 6.53												
Y	30.00	1.24	5.24	11.24	17.24	29.24	41.24	53.24	65.24	77.24	101.24	
L1	30.00	19.74	23.74	29.74	35.74	47.74	59.74	71.74	83.74	95.74	119.74	
L2	30.00	30.99	34.99	40.99	46.99	58.99	70.99	82.99	94.99	106.99	130.99	
Z	30.00	37.34	40.81	46.00	51.20	61.59	71.98	82.38	92.77	103.16	123.94	
MINIMUM H = 10.01												
Y	45.00			0.63	4.87	13.35	21.84	30.32	38.81	47.29	64.27	
L1	45.00					33.02	41.50	49.99	58.47	66.96	83.93	
L2	45.00					49.90	58.39	66.87	75.36	83.84	100.81	
Z	45.00					50.31	56.31	62.31	68.31	74.31	86.31	
MINIMUM H = 18.60												
Y	60.00					4.20	11.13	18.06	24.99	31.91	45.77	
L1	60.00						32.33	39.26	46.19	53.11	66.97	
L2	60.00						54.84	61.77	68.70	75.63	89.49	
Z	60.00						50.65	54.11	57.57	61.04	67.97	
MINIMUM H = 28.86												
Y	90.00							3.75	9.75	15.75	27.75	
L1	90.00										50.77	
L2	90.00										84.54	
Z	90.00										51.50	
MINIMUM H = 51.5												

Special Bending Information Chart (cont'd)

DIM	ANGLE	HEIGHT – H									
		10"	12"	15"	18"	24"	30"	36"	42"	48"	60"
2-1/2 IMC/RIGID		Dia. = 2.875		Radius = 13.9		x = 6.15					
Y	15.00	25.10	32.83	44.42	56.01	79.19	102.38	125.56	148.74	171.92	218.29
L1	15.00	38.62	46.34	57.93	69.53	92.71	115.89	139.07	162.25	185.44	231.8
L2	15.00	42.26	49.98	61.57	73.16	96.35	119.53	142.71	165.89	189.08	235.44
Z	15.00	47.13	54.59	65.79	76.99	99.38	121.77	144.16	166.56	188.95	233.73
MINIMUM H = 2.54											
Y	22.50	13.46	18.69	26.53	34.37	50.04	65.72	81.40	97.08	112.76	144.12
L1	22.50	26.06	31.29	39.13	46.97	62.64	78.32	94.00	109.68	125.36	156.72
L2	22.50	31.52	36.74	44.58	52.42	68.10	83.78	99.46	115.14	130.82	162.17
Z	22.50	35.82	40.65	47.89	55.14	69.62	84.11	98.59	113.08	127.56	156.53
MINIMUM H = 4.47											
Y	30.00	7.25	11.25	17.25	23.25	35.25	47.25	59.25	71.25	83.25	107.25
L1	30.00	19.83	23.83	29.83	35.83	47.83	59.83	71.83	83.83	95.83	119.83
L2	30.00	27.11	31.11	37.11	43.11	55.11	67.11	79.11	91.11	103.11	127.11
Z	30.00	30.92	34.38	39.58	44.78	55.17	65.56	75.95	86.35	96.74	117.52
MINIMUM H = 6.80											
Y	45.00	0.20	3.03	7.27	11.52	20.00	28.49	36.97	45.46	53.94	70.91
L1	45.00			20.62	24.86	33.34	41.83	50.31	58.80	67.28	84.25
L2	45.00			31.53	35.77	44.26	52.75	61.23	69.72	78.20	95.17
Z	45.00			32.67	35.67	41.67	47.67	53.67	59.67	65.67	77.67
MINIMUM H = 12.49											
Y	60.00			1.49	4.95	11.88	18.81	25.73	32.66	39.59	53.45
L1	60.00					26.22	33.15	40.07	47.00	53.93	67.79
L2	60.00					40.77	47.70	54.63	61.56	68.49	82.34
Z	60.00					36.06	39.52	42.98	46.45	49.91	56.84
MINIMUM H = 19.23											
Y	90.00					2.51	8.51	14.51	20.51	26.51	38.51
L1	90.00							30.03	36.03	42.03	54.03
L2	90.00							51.87	57.87	63.87	75.87
Z	90.00							33.95	33.95	33.95	33.95
MINIMUM H = 33.95											
3 IMC/RIGID		Dia. = 3.5		Radius = 16.48		x = 6					
Y	15.00	23.71	31.43	43.02	54.62	77.80	100.98	124.16	147.34	170.53	216.89
L1	15.00	38.61	46.34	57.93	69.52	92.70	115.89	139.07	162.25	185.43	231.80
L2	15.00	42.93	50.65	62.25	73.84	97.02	120.20	143.38	166.57	189.75	236.11
Z	15.00	47.66	55.12	66.32	77.52	99.91	122.30	144.69	167.09	189.48	234.26
MINIMUM H = 2.68											
Y	22.50	12.28	17.51	25.35	33.19	48.86	64.54	80.22	95.90	111.58	142.94
L1	22.50	26.05	31.27	39.11	46.95	62.63	78.31	93.99	109.67	125.35	156.70
L2	22.50	32.52	37.74	45.58	53.42	69.10	84.78	100.46	116.14	131.82	163.17
Z	22.50	36.70	41.53	48.77	56.01	70.50	84.98	99.47	113.95	128.44	157.41
MINIMUM H = 4.81											
Y	30.00	6.08	10.08	16.08	22.08	34.08	46.08	58.08	70.08	82.08	106.08
L1	30.00	19.80	23.80	29.80	35.80	47.80	59.80	71.80	83.80	95.80	119.80
L2	30.00	28.43	32.43	38.43	44.43	56.43	68.43	80.43	92.43	104.43	128.43
Z	30.00	32.15	35.62	40.81	46.01	56.40	66.79	77.19	87.58	97.97	118.75
MINIMUM H = 7.42											
Y	45.00		1.67	5.91	10.15	18.64	27.13	35.61	44.10	52.58	69.55
L1	45.00			20.50	24.75	33.23	41.72	50.20	58.69	67.17	84.14
L2	45.00			33.45	37.69	46.18	54.66	63.15	71.63	80.12	97.09
Z	45.00			34.65	37.65	43.65	49.65	55.65	61.65	67.65	79.65
MINIMUM H = 13.90											
Y	60.00				3.25	10.18	17.11	24.03	30.96	37.89	51.75
L1	60.00					25.94	32.87	39.80	46.73	53.65	67.51
L2	60.00					43.20	50.13	57.06	63.98	70.91	84.77
Z	60.00					38.89	42.35	45.81	49.28	52.74	59.67
MINIMUM H = 21.68											
Y	90.00						5.77	11.77	17.77	23.77	35.77
L1	90.00								34.93	40.93	52.93
L2	90.00								60.81	66.81	78.81
Z	90.00								38.96	38.96	38.96
MINIMUM H = 38.96											



881 and 881CT Cam Track® Hydraulic Benders

Special Bending Information Chart (cont'd)

		HEIGHT - H										
DIM	ANGLE	10"	12"	15"	18"	24"	30"	36"	42"	48"	60"	
3-1/2 IMC/RIGID		Dia. = 4		Radius = 19.18			x = 7					
Y	15.00	21.38	29.11	40.70	52.29	75.48	98.66	121.84	145.02	168.21	214.57	
L1	15.00	38.61	46.34	57.93	69.52	92.70	115.88	139.06	162.25	185.43	231.79	
L2	15.00	43.63	51.36	62.95	74.54	97.72	120.90	144.09	167.27	190.45	236.81	
Z	15.00	49.37	56.83	68.03	79.23	101.62	124.01	146.40	168.80	191.19	235.97	
MINIMUM H = 3.12												
Y	22.50	10.09	15.32	23.16	30.99	46.67	62.35	78.03	93.71	109.39	140.75	
L1	22.50	26.03	31.26	39.10	46.94	62.62	78.30	93.97	109.65	125.33	156.69	
L2	22.50	33.56	38.79	46.63	54.47	70.15	85.83	101.51	117.18	132.86	164.22	
Z	22.50	38.77	43.60	50.84	58.09	72.57	87.06	101.54	116.03	130.51	159.48	
MINIMUM H = 5.60												
Y	30.00	3.86	7.86	13.86	19.86	31.86	43.86	55.86	67.86	79.86	103.86	
L1	30.00	19.76	23.76	29.76	35.76	47.76	59.76	71.76	83.76	95.76	119.76	
L2	30.00	29.91	33.81	39.81	45.81	57.81	69.81	81.81	93.81	105.81	129.81	
Z	30.00	34.60	38.06	43.26	48.46	58.85	69.24	79.63	90.02	100.42	121.20	
MINIMUM H = 8.64												
Y	45.00			3.44	7.68	16.17	24.65	33.14	41.62	50.11	67.08	
L1	45.00				24.63	33.12	41.60	50.09	58.57	67.06	84.03	
L2	45.00				39.69	48.18	56.67	65.15	73.64	82.12	99.09	
Z	45.00				40.89	46.89	52.89	58.89	64.89	70.89	82.89	
MINIMUM H = 16.19												
Y	60.00				0.40	7.33	14.26	21.19	28.11	35.04	48.90	
L1	60.00					32.58	39.51	46.44	53.36	67.22		
L2	60.00					52.66	59.59	66.52	73.45	87.31		
Z	60.00					46.47	49.93	53.40	56.86	63.79		
MINIMUM H = 25.24												
Y	90.00						1.82	7.82	13.82	19.82	31.82	
L1	90.00							39.77	51.77			
L2	90.00							69.90	81.90			
Z	90.00							45.36	45.36			
MINIMUM H = 45.36												
4 IMC/RIGID		Dia. = 4.5		Radius = 21.5			x = 8.75					
Y	15.00	18.36	26.09	37.68	49.27	72.46	95.64	118.82	142.00	165.18	211.55	
L1	15.00	38.60	46.33	57.92	69.51	92.70	115.88	139.06	162.24	185.43	231.79	
L2	15.00	44.23	51.96	63.55	75.14	98.33	121.51	144.69	167.87	191.05	237.42	
Z	15.00	51.73	59.20	70.39	81.59	103.98	126.37	148.76	171.16	193.55	238.33	
MINIMUM H = 3.73												
Y	22.50	7.23	12.45	20.29	28.13	43.81	59.49	75.17	90.85	106.52	137.88	
L1	22.50	26.02	31.25	39.09	46.93	62.60	78.28	93.96	109.64	125.32	156.68	
L2	22.50	34.46	39.69	47.53	55.37	71.05	86.73	102.41	118.08	133.76	165.12	
Z	22.50	41.45	46.27	53.52	60.76	75.24	89.73	104.21	118.70	133.19	162.16	
MINIMUM H = 6.62												
Y	30.00	0.99	4.99	10.99	16.99	28.99	40.99	52.99	64.99	76.99	100.99	
L1	30.00		23.74	29.74	35.74	47.74	59.74	71.74	83.74	95.74	119.74	
L2	30.00		34.99	40.99	46.99	58.99	70.99	82.99	94.99	106.99	130.99	
Z	30.00		41.06	46.25	51.45	61.84	72.23	82.63	93.02	103.41	124.19	
MINIMUM H = 10.13591												
Y	45.00			0.38	4.62	13.10	21.59	30.07	38.56	47.04	64.02	
L1	45.00					33.02	41.50	49.99	58.47	66.96	83.93	
L2	45.00					49.90	58.39	66.87	75.36	83.84	100.81	
Z	45.00					50.56	56.56	62.56	68.56	74.56	86.56	
MINIMUM H = 18.78												
Y	60.00					3.95	10.88	17.81	24.74	31.66	45.52	
L1	60.00						32.33	39.26	46.19	53.11	66.97	
L2	60.00						54.84	61.77	68.70	75.63	89.49	
Z	60.00						50.90	54.36	57.82	61.29	68.22	
MINIMUM H = 29.08												
Y	90.00							3.50	9.50	15.50	27.50	
L1	90.00										50.77	
L2	90.00										84.54	
Z	90.00										51.75	
MINIMUM H = 51.75												

Troubleshooting

PROBLEM	PROBABLE CAUSE	PROBABLE REMEDY
Wrinkling of EMT.	<p>Shoe pin in wrong position.</p> <p>Follow bar in backwards.</p> <p>Contact surfaces between shoe and follow bar have debris or damage.</p> <p>Follow bar is not positioned within 1" of saddle at start of bend.</p> <p>Follow bar is not centered on roller at start of bend.</p> <p>Shoe or follow bar grooves are worn or spread.</p> <p>Roller is not rolling on shaft.</p> <p>High yield strength conduit.</p>	<p>Move shoe pin to hole marked EMT.</p> <p>Remove follow bar and insert end marked START toward saddle.</p> <p>Clean shoe and follow bar. Replace shoe or follow bar as necessary.</p> <p>Position follow bar according to the bending instructions.</p> <p>Center the follow bar on the roller.</p> <p>Replace shoe or follow bar.</p> <p>Lubricate roller.</p> <p>Use standard EMT.</p>
Side creasing of EMT.	<p>Follow bar is not centered on roller at start of bend.</p> <p>Conduit is not level (when bending on the floor).</p> <p>Contact surfaces between shoe and follow bar have debris or damage.</p> <p>Pipe vise unit of 1813 is clamped too close to bender.</p> <p>Follow bar groove worn or spread.</p>	<p>Center the follow bar on the roller.</p> <p>Level the conduit.</p> <p>Clean shoe and follow bar. Replace shoe or follow bar as necessary.</p> <p>Move the pipe vise unit further from the bender.</p> <p>Replace follow bar.</p>
Won't bend EMT.	<p>Follow bar is in backwards.</p>	<p>Remove follow bar and insert end marked START toward saddle.</p>

Troubleshooting (cont'd)

PROBLEM	PROBABLE CAUSE	PROBABLE REMEDY
Wrinkling of IMC or rigid.	Follow bar is in backwards.	Remove follow bar and insert end marked START toward saddle.
Side creasing of IMC or rigid.	Conduit is not level (when bending on floor).	Level the conduit.
	Follow bar not centered on roller at start of bend.	Center the follow bar on the roller.
Won't bend IMC or rigid.	Shoe pin in wrong position.	Move shoe pin to hole marked IMC/RIGID.
	Follow bar is in backwards.	Remove follow bar and insert end marked START toward saddle.
Ram will not advance.	Pump does not have enough oil.	Add oil. See instructions supplied with the pump.
	Pump vent is closed.	Open the pump vent.
	Hose couplings not fully tightened.	Tighten the hose couplings.
	Excessive voltage drop from long extension cord.	Use a shorter or heavier extension cord.

Identification—Major Components

881 and 881CT Cam Track® Hydraulic Bender

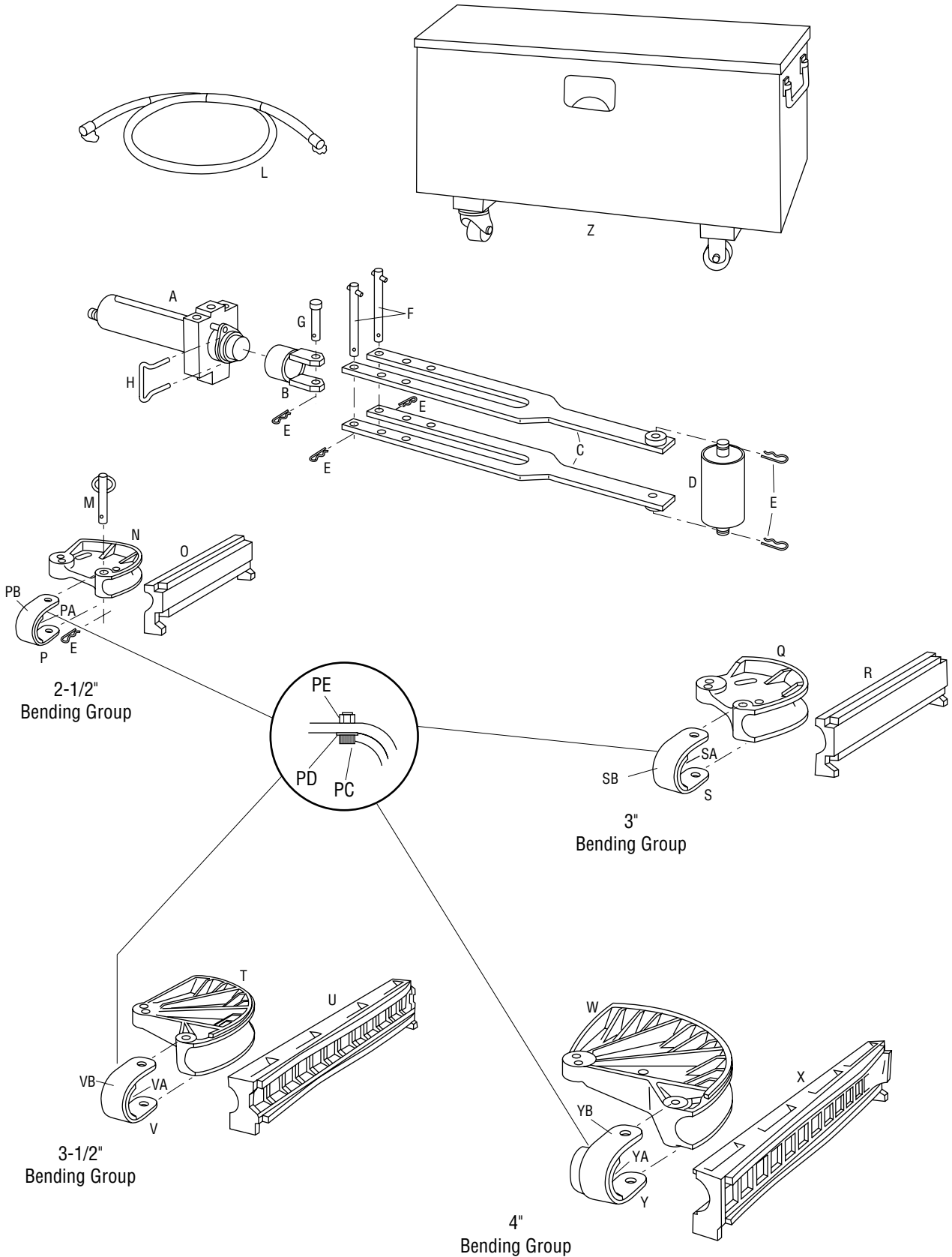

Parts List—881 and 881CT

Key	Part No.	Description	Qty
A	502 7416.3	Ram, 40-ton (see separate parts list)	1
B	503 0309.0	Yoke	1
C	502 6309.9	Connecting bar unit (includes the next three items)	2
	502 6628.4	Bushing	2
	905 2932.4	Screw, cap, 5/16–18 x .750 socket head	4
	500 2754.9	Decal, warning	2
D	502 7364.7	Roller unit (includes two Key E)	1
E	905 0302.3	Clip, hitch pin, #8	6
F	502 7381.7	Cylinder block pin unit (includes one Key E)	2
G	502 6306.4	Pin, yoke, 1.24 x 5.80	1
H	502 6349.8	Clip, spring	1
L	501 1289.9	Hose unit, 3/8 x 6' with couplers (includes the following two items)	1
	905 0760.6	Hose, hydraulic, 3/8 x 6', 3/8 M NPTF	1
	905 0823.8	Coupler, quick, 3/8 male	2
M	502 6624.1	Saddle pin unit (includes the following item)	1
	905 0302.3	Clip, hitch pin, #8	1



Shoe Groups for the 881 and 881CT

Key	Part No.	Description	Qty
	502 7554.2	2-1/2" One-shot 90° shoe group (13-1/2" centerline bending radius)	
N	502 6297.1	2-1/2" Shoe.....	1
O	502 6366.8	2-1/2" Follow bar unit (includes the following two items)	1
	502 6364.1	Bar, reinforcement, 2-1/2"	2
	905 0226.4	Screw, cap, 5/16–18 x 1.25 socket head	6
P	502 6580.6	2-1/2" Saddle (includes PA, PB, PC)	1
PA	502 6583.0	2-1/2" Saddle insert	1
PB	502 6581.4	2-1/2" Saddle strap	1
PC	905 1088.7	Screw, cap	2
	502 7555.0	3" One-shot 90° shoe group (16" centerline bending radius)	
PD	905 0028.8	Lock washer	2
PE	905 2646.5	Lock nut	2
Q	502 6300.5	3" Shoe	1
R	503 5400.0	3" Follow bar +	1
		+ to order both reinforcement bars for this follow bar, order the following item:	
	503 5467.1	Conversion kit, 3" reinforcement bar	
S	502 6584.9	3" Saddle (includes SA, SB, PC)	1
SA	502 6587.3	3" Saddle insert	1
SB	502 6585.7	3" Saddle strap	1
PC	905 1088.7	Screw, cap	2
PD	905 0028.8	Lock washer	2
PE	905 2646.5	Lock nut	2



Shoe Groups for the 881CT Only

Key	Part No.	Description	Qty
	503 1281.2	3-1/2" One-shot 90° shoe group (18-5/8" centerline bending radius) (includes T, U, V)	
T	503 1882.9	3-1/2" Shoe.....	1
U	503 1278.2	3-1/2" Follow bar (to replace, order 503 1881.0) ...	1
	503 1277.4	Bar, reinforcement 3-1/2"	2
	905 0224.8	Screw, cap, 5/16-18 x 1.00 socket head	4
	905 0226.4	Screw, cap, 5/16-18 x 1.25 socket head	2
V	502 6588.1	3-1/2" Saddle (includes the next two items and PC)	1
VA	502 6593.8	3-1/2" Saddle insert	1
VB	502 6590.3	3-1/2" Saddle strap	1
PC	905 1088.7	Screw, cap	2
PD	905 0028.8	Lock washer	2
PE	905 2646.5	Lock nut	2
	503 1274.0	4" One-shot 90° shoe group (20-7/8" centerline bending radius) (includes W, X, Y)	
W	503 1884.5	4" Shoe	1
X	503 1271.5	4" Follow bar (to replace, order 503 1883.7)	1
	503 1270.7	Bar, reinforcement, 4"	2
	905 0224.8	Screw, cap, 5/16-18 x 1.00 socket head	4
	905 0226.4	Screw, cap, 5/16-18 x 1.25 socket head	2
Y	502 6594.6	4" Saddle (includes the next two items and PC) ...	1
YA	502 6597.0	4" Saddle insert	1
YB	502 6595.4	4" Saddle strap	1
PC	905 1088.7	Screw, cap	2
PD	905 0028.8	Lock washer	2
PE	905 2646.5	Lock nut	2



Shoe Groups for the 881CT Only

Key	Part No.	Description	Qty
	502 7556.9	3-1/2" Shoe group (18-5/8" centerline bending radius) (includes T, U, V)	
T	502 6302.1	3-1/2" Shoe.....	1
U	502 6389.7	3-1/2" Follow bar unit (includes the following two items)	1
	502 6392.7	Bar, reinforcement, 3-1/2"	2
	905 0226.4	Screw, cap, 5/16–18 x 1.25 socket head	6
	502 7557.7	4" Shoe group (21" centerline bending radius) (includes W, X, Y)	
W	502 6305.6	4" Shoe	1
X	503 1292.8	4" Follow bar unit (includes the following two items)	1
	503 1293.6	Bar, reinforcement, 4"	2
	905 0226.4	Screw, cap, 5/16–18 x 1.25 socket head	6
Z	502 3363.7	Box, job	1
	503 0239.6	Set, casters (two rigid, two swivel)	1

Exploded View—Ram

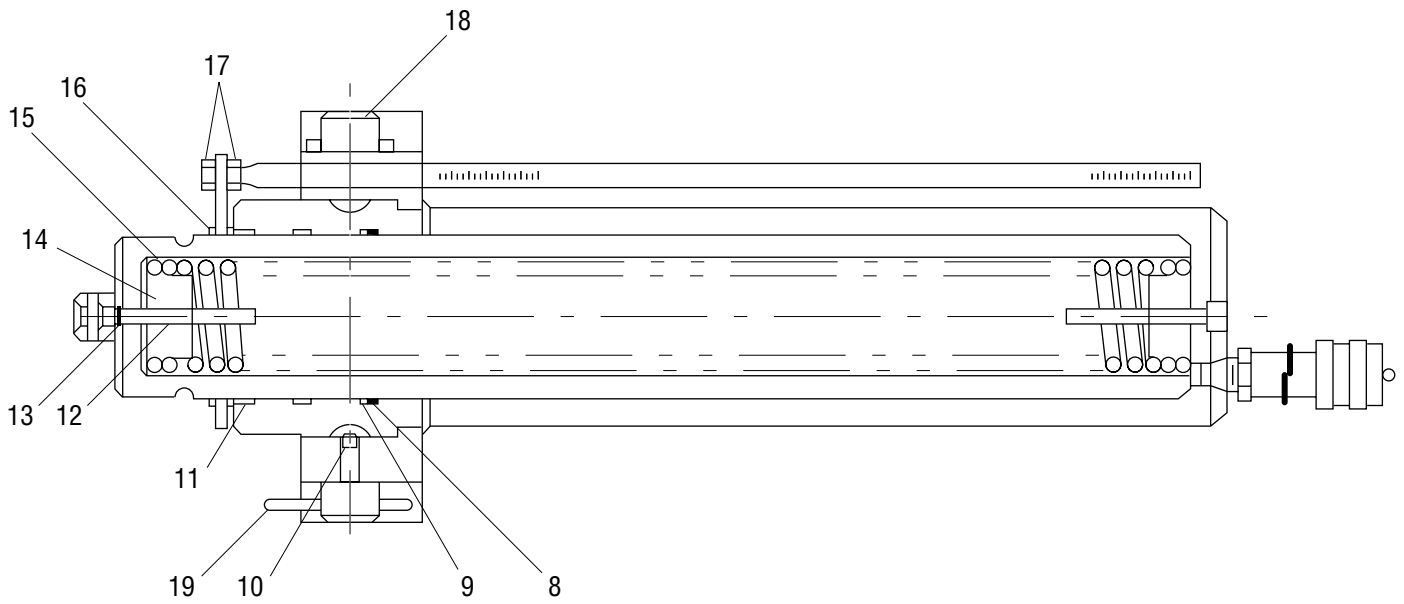
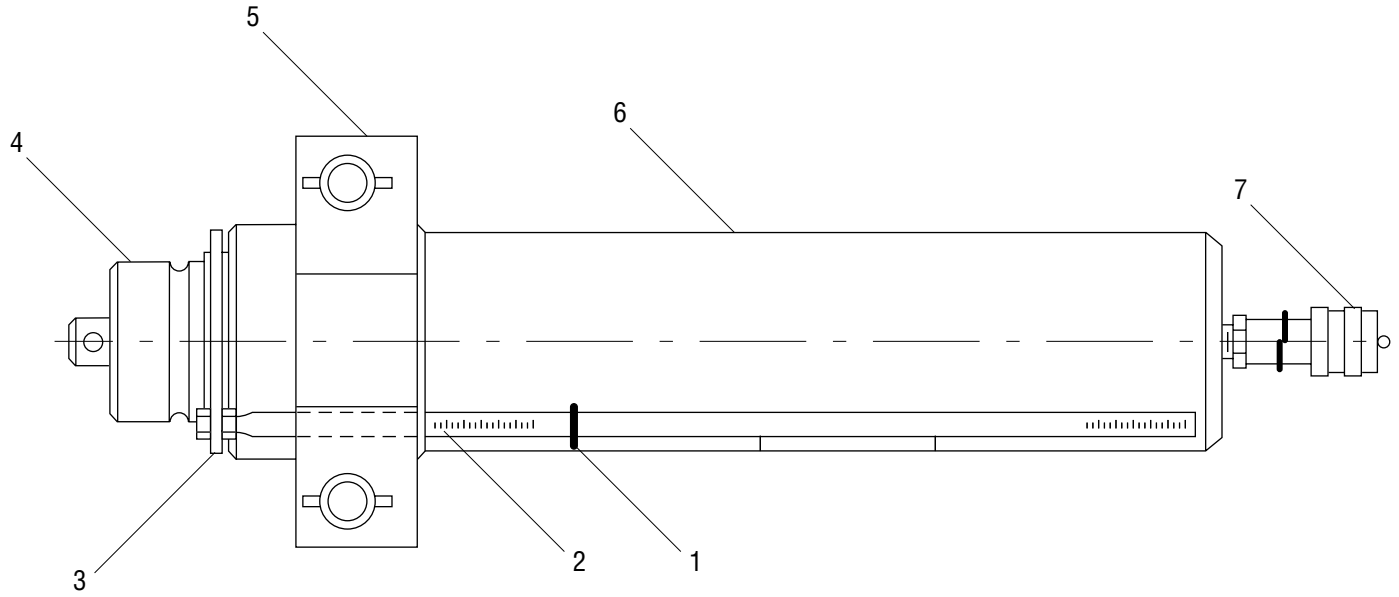



Parts List—Ram (502 7416.3)

Key	Part No.	Description	Qty
1	905 2867.0	O-ring, .437 x .625 x .093	1
2	502 1948.0	Scale, piston	1
3	502 1949.9	Bracket, scale	1
4	501 6266.7	Piston, hydraulic	1
5	502 7417.1	Block, cylinder	1
6	501 6267.5	Cylinder, hydraulic	1
7	905 0807.6	Coupler, quick, 3/8" female	1
8	905 0830.0	O-ring, 3.25 x 3.62 x .187	1
9	905 0829.7	Back-up ring, spiral, 3.25 x 3.62 x .185	1
10	905 2217.6	Screw, set, 3/8–16 x .500 socket	1
11	501 7205.0	Liner, cylinder	1
12*	501 0670.8	Screw, tension spring	2
12A*	500 3140.6	Screw, tension spring	2
13*	500 3420.0	Washer, flat, .321 x .428 x .040 nylon.....	2
13A*	501 3496.5	Washer, flat, .321 x .460 x .040 nylon.....	2
14	501 0662.7	Retainer, spring	2
15	501 0661.9	Spring, extension, 1.70 x 2.33 x 16.6.....	1
16	905 1248.0	Ring, retaining, 3.25 Truarc.....	4
17	905 0848.3	Nut, hex, 3/8–24 light jam	2
18	502 7381.7	Pin unit, cylinder block, 1.13 x 10.2 (includes key 19)	2
19	905 0302.3	Clip, hitch pin #8	2
	502 3560.5	Decal (not shown)	1
	503 4316.5	Decal, read IM (not shown)	1
	503 5499.0	Decal, Warning (not shown)	1
	501 3797.2	Packing kit, repair (includes 8, 9, 12, and 12A)	

* Items 12 and 13 were used prior to April 1997;
 items 12A and 13A have been used since
 April 1997. Use 12A and 13A if possible.

Exploded View—1813 Bending Table (502 8901.2)

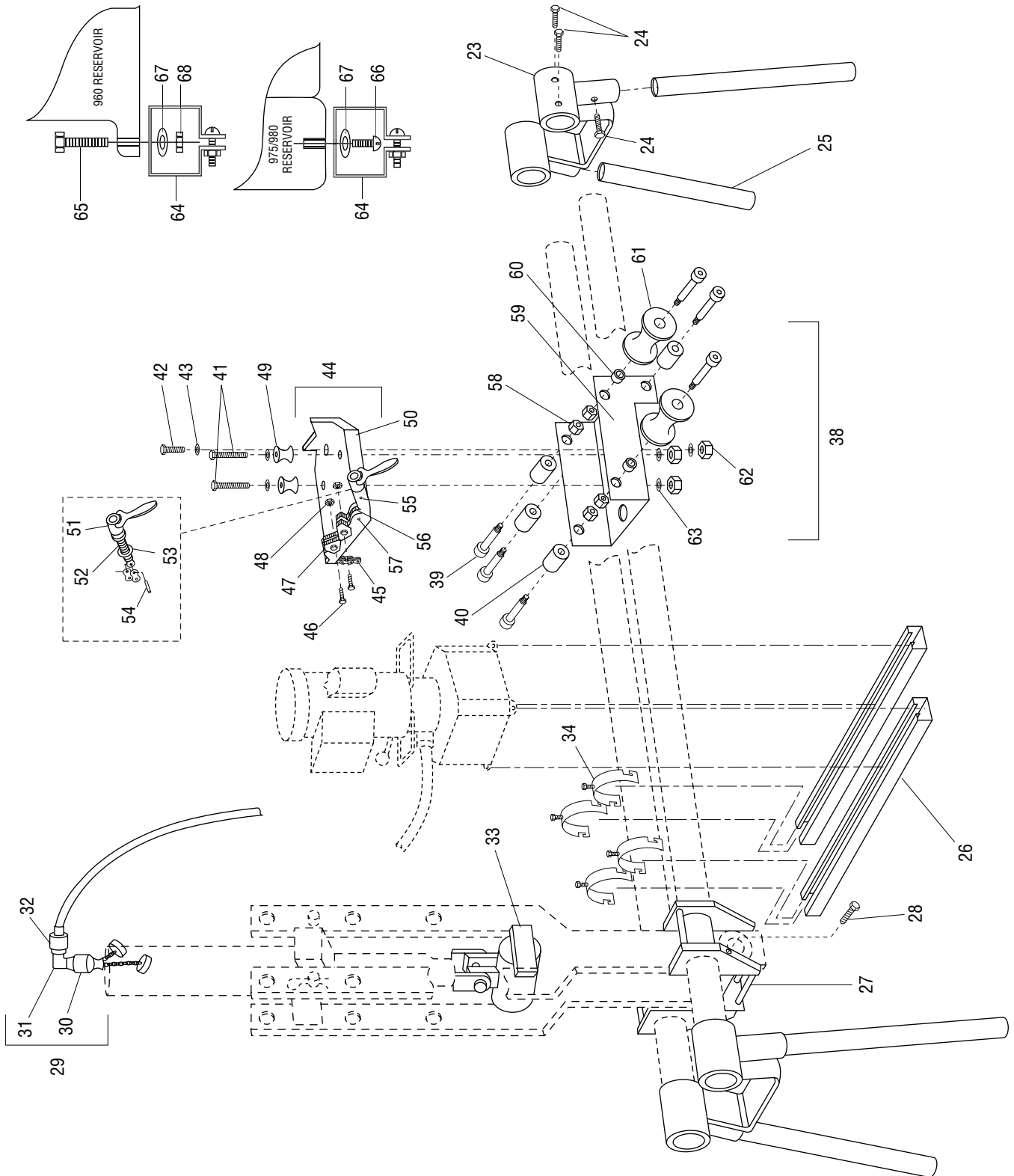

**Parts List—1813 Bending Table (502 8901.2)**

Key	Part No.	Description	Qty
23	502 1541.8	Leg support unit (includes key 24)	2
24	905 1787.3	Screw, cap, 1/2–13 x 1.00 hex head	12
25	502 1346.6	Leg	4
26	502 9004.5	Support, pump table	2
27	502 8885.7	Mounting unit, bender (includes key 28)	1
28	905 0532.8	Screw, cap, 3/8–16 x 1.25 hex head	2
29	502 9014.2	Fitting unit, hydraulic coupling (includes keys 30-32)	1
30	905 0807.6	Coupler, quick, 3/8" female	1
31	905 1137.9	Elbow, 3/8 NPTF 90° street	1
32	905 0823.8	Coupler, quick, 3/8" male	1
33	502 9022.3	Positioner, ram	1
34	905 4766.7	Clamp, pipe	4
35	502 1318.0	Gage, bending (not shown)	1
36	502 3274.6	Box (not shown)	1
37	503 5132.0	Decal, identification (not shown)	1
38	502 8900.4	Vise unit, pipe (includes keys 39-63)	1
39	905 1788.1	Screw, shoulder, .750 x 2.75 x 5/8–11	6
40	502 4720.4	Roller, .767 x 2.50 x 2.12	2
41	905 2471.3	Screw, cap, 1/2–13 x 3.25 hex head	2
42	905 0544.1	Screw, cap, 1/2–13 x 1.50 hex head	1
43	905 1510.2	Washer, flat, .531 x 1.06 x .093	3
44	502 7994.7	Vise unit, bench (includes keys 45-57)	1
45	502 4971.1	Chain, leaf, 23"	1
46	905 1166.2	Screw, cap, 5/16–18 x 2.00 hex head	2
47	502 9003.7	Jaw, vise	4
48	905 0638.3	Nut, hex, 5/16–18, full	2
49	502 7372.8	Spool, .656 x 1.50 x 1.87	2
50	502 7316.7	Table, vise chain	1
51	502 5550.9	Handle unit, vise chain	1
52	502 5553.3	Screw, vise chain	1
53	502 4987.8	Spacer, .775 x 1.23 x .062	1
54	502 6430.3	Pin, chain, .242 x .750	1
55	905 0420.8	Pin, roll, .125 x 1.00	1
56	502 4985.1	Roller, .390 x .998 x .625	1
57	905 3160.4	Pin, drive, .375 x 1.75	1
58	905 2610.4	Nut, hex, 5/8–11 lock head thin	4
59	502 8893.8	Carriage unit	1
60	502 1351.2	Spacer, .824 x 1.05 x .38	2
61	502 4765.4	Roller, .767 x 1.50 x 2.68	4
62	905 2794.1	Nut, hex, 1/2–13 zinc-plated	3
63	905 0507.7	Washer, lock, .516 x .871 x .099 spring	3
	501 2121.9	Decal, Safety (not shown)	1
64	905 3824.2	Bracket, pump	4
65	905 0975.7	Screw, cap, 1/4–20 x 1.00 hex head (for the 960 SAPS pump)	4
66	905 1185.9	Screw, machine, 1/4–20 x .500 round head (for the 980 pump)	4
67	905 1674.5	Washer, lock, .259 x .489 x .062	4
68	905 1593.5	Nut, hex, 1/4–20 steel (for the 960 SAPS pump)	4

Decals**For the 881 (502 7778.2)**

Part No.	Description	Qty
502 6598.9	Decal, bender ram travel	1
502 6599.7	Decal, parts list	1
502 6601.2	Decal, bender offset	1
502 6602.0	Decal, bender 90° stub	1
503 2688.0	Decal, Caution	1
503 5139.7	Decal, identification	1

For the 881CT (503 1287.1)

Part No.	Description	Qty
503 1304.5	Decal, bender ram travel	1
503 1306.1	Decal, parts list	1
503 1909.4	Decal, offset	1
503 2688.0	Decal, Caution	1
503 5141.9	Decal, identification	1

On the Ram (502 7416.3)

Part No.	Description	Qty
502 3560.5	Decal, Greenlee	1
503 4316.5	Decal, read IM	1
503 5499.0	Decal, Warning	1

On the Job Box (502 3363.7)

Part No.	Description	Qty
500 0994.0	Decal, Danger	1
500 1057.3	Decal, Warning	1
502 6410.9	Decal, identification	1
503 5102.8	Decal, Greenlee	1

