



MANUAL PART NUMBER: 400-0180-001

CCH100

CABLE CATCHER

USER'S GUIDE

PRECAUTIONS / SAFETY WARNINGS 1

Please read this manual carefully before using your **CCH100** Cable Catcher. Keep this manual handy for future reference. These safety instructions are to ensure the long life of your **CCH100** Cable Catcher. Please read them carefully and heed all warnings.

1.1. GENERAL

- There are no user serviceable parts inside. Only qualified ALTINEX service personnel must do all service on the **CCH100** Cable Catcher.

1.2. INSTALLATION

- For best results, place the **CCH100** Cable Catcher on a flat, leveled surface in a dry area away from dust and moisture.
- Do not place the **CCH100** Cable Catcher in direct sunlight, near heaters or heat radiating appliances, or near any liquid.
- Exposure to direct sunlight, smoke, or steam can harm the **CCH100** Cable Catcher.

1.3 CLEANING

- Clean surfaces with a dry cloth. Never use strong detergents or solvents, such as alcohol or thinner. Do not use a wet cloth or water to clean the unit.

1.4 FCC / CE NOTICE

- This device complies with part 15 of the FCC Rules. Operation is subject to the following two conditions: (1) This device may not cause harmful interference, and (2) this device must accept any interference received, including interference that may cause undesired operation.
- This equipment has been tested and found to comply with the limits for a Class A digital device, pursuant to Part 15 of the FCC Rules. These limits are designed to provide reasonable protection against harmful interference when the equipment is operated in a commercial environment. This equipment

generates, uses, and can radiate radio frequency energy and, if not installed and used in accordance with the instruction manual, may cause harmful interference to radio communications. Operation of this equipment in a residential area is likely to cause harmful interference in which case the user will be required to correct the interference at his own expense.

- Any changes or modifications to the unit not expressly approved by ALTINEX, Inc. could void the user's authority to operate the equipment.

ABOUT YOUR CCH100 2

Designed to make computer and A/V equipment connectors more accessible, the **CCH100** Cable Catcher™ allows easy access to cable ends by holding them at the edge of a table or desk. The adjustable rack accommodates various sizes of cables. The screw-tight clamp accommodates a table or desk thickness of up to 1.5 inches (4 cm).

The **CCH100** Cable Catcher allows your most commonly-used cable ends to be easily accessible, and eliminates the need to crawl behind desks or under tables to reach less-than-convenient data and A/V connectors. By running cables up to the desktop and through the Cable Catcher, each signal is conveniently within reach, ready to be accessed and re-routed as your needs for it change. The **CCH100** Cable Catcher is offered in a standard black anodized finish.

DESCRIPTION DIAGRAM

3

DIAGRAM 1

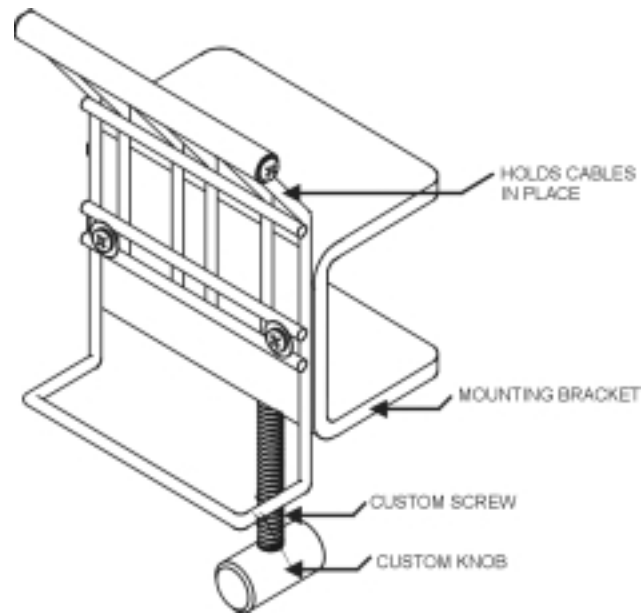
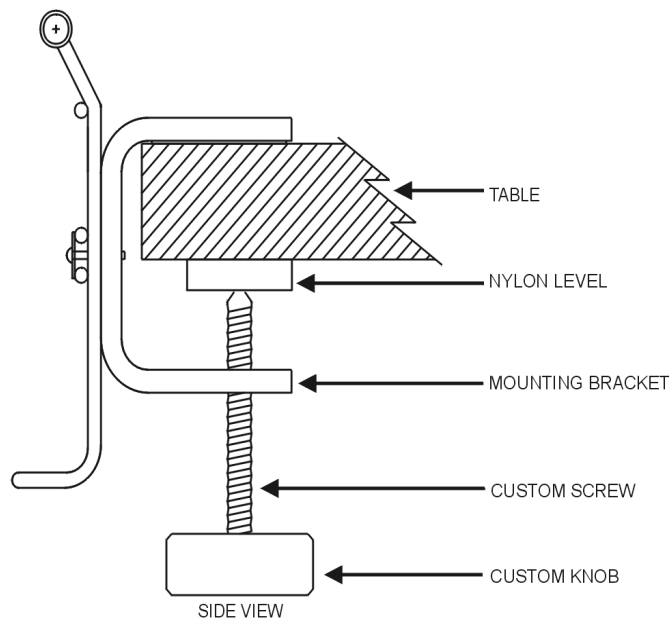

DIAGRAM 2



- Step 1.** Attach the unit to the table using the mounting bracket.
- Step 2.** Place the nylon level underneath the table. Insert the custom screw through the mounting bracket to the nylon level (see diagram 2).
- Step 3.** Secure the unit to the table using the custom knob.
- Step 4.** Place cables inside **CCH100** Cable Catcher. The aluminum wire will hold cables in place.